

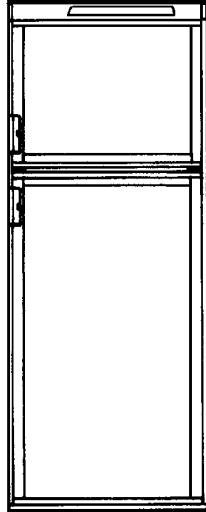

RECORD THIS INFORMATION FOR FUTURE REFERENCE  
BEFORE INSTALLING THE UNIT:  
Model No. \_\_\_\_\_ Serial No. \_\_\_\_\_  
Date Purchased \_\_\_\_\_ Place of Purchase \_\_\_\_\_



**MODEL RM2612 AND RM2812  
Automatic/Manual Energy Selector**

**REFRIGERATOR FOR LP/GAS  
AND ELECTRIC OPERATION**

**USA**  
SERVICE OFFICE  
The Dometic Corp.  
509 So. Poplar St.  
LaGrange, IN 46761

**CANADA**  
Dometic Dist.  
866 Langs Dr.  
Cambridge, Ontario  
CANADA N3H 2N7



**FOR YOUR SAFETY**  
If you smell gas:

1. Shut off gas supply at main valve.
2. Open windows.
3. Don't touch electrical switches.
4. Extinguish any open flame.
5. Immediately call your gas supplier.

**WARNING**  
Improper installation, adjustment, alteration, service or maintenance can cause injury or property damage. Refer to this manual. For assistance or additional information consult a qualified installer, service agency or the gas supplier.

**FOR YOUR SAFETY**  
Do not store or use gasoline or other flammable vapors and liquids in the vicinity of this or any other appliance.

**AVIS**  
Cet appareil doit être réparé seulement par un réparateur autorisé. Modification de l'appareil pourrait être extrêmement dangereuse, et pourrait causer mal ou mort.

**REFRIGERATOR  
MODEL  
RM2612  
RM2812**

**INSTALLATION &  
OPERATING INSTRUCTIONS**

INDEX	Page
Installation .....	2
Operating Instructions .....	7
Maint. & Service .....	10
Wiring Diagram .....	12

**IMPORTANT INSTRUCTIONS  
READ CAREFULLY**

# SECTION A. INSTALLATION

## 1. GENERAL INSTRUCTIONS

**This appliance is designed for storage of foods and storage of frozen foods and making ice.**

The refrigerators outlined herein have been design certified by A.G.A. under ANSI Z21.19 Refrigerator Standard for installation in a mobile home or recreational vehicle and are approved by the Canadian Gas Association.

The certifications are, however, contingent on the installation being made in accordance with the following instructions as applicable.

**In the U.S.A., the installation must conform with:**

1. National Fuel Gas Code ANSI Z223.1-(latest edition)
2. Manufactured Home Construction and Safety Standard, Title 24 CFR, Part 3280
3. Recreational Vehicles ANSI A119.2-(latest edition).

The unit must be electrically grounded in accordance with the National Electric Code ANSI/NFPA 70-(latest edition) when installed if an external alternating current electrical source is utilized.

4. Any applicable local code.

**In Canada, the installation must conform with:**

1. Current CGA B 149 Gas Installation Codes
2. Current CSA Standard Z 240.4 GAS-EQUIPPED RECREATIONAL VEHICLES AND MOBILE HOUSING
3. Any applicable local code

The unit must be electrically grounded in accordance with the CANADIAN ELECTRICAL CODE C 22 Parts 1 and 2.

## 2. VENTILATION

The installation shall be made in such a manner as to separate the combustion system from the living space of the mobile home or recreational vehicle. Openings in lower side vent for air supply or for venting of combustion products shall have a minimum dimension of not less than 1/4 inch.

Proper installation requires one fresh air intake and one upper exhaust vent. The ventilation kits shown in this instruction manual have been certified for use with the refrigerator model listed in the Table. For "Certified Vent System Kits" see Section B. The ventilation kits must be installed and used without modification. An opening toward the outside at floor level in the refrigerator compartment must be provided for ventilation of heavier-than-air fuel gases. The lower vent of the recommended kits is provided with proper size openings. The flow of combustion and ventilation air must not be obstructed.

The lower side vent is fitted with a panel which provides an adequate access opening for ready serviceability of the burner and control manifold of the refrigerator. This should be centered on the back of the refrigerator.

## 3. CERTIFIED INSTALLATION

Certified installations require one roof vent and one lower side vent.

**For certified vent system kits, see Section B.**

For further information, contact your dealer or distributor.

## 4. METHOD OF INSTALLATION

The method of installation is shown in FIG. 1. It is essential that all maximum or minimum dimensions are strictly maintained as the performance of the refrigerator is dependent on adequate flow of air over the rear of the refrigerator.

**NOTE: The upper vent should be centered over the condenser coil at the back of the refrigerator.**

FIG. 1

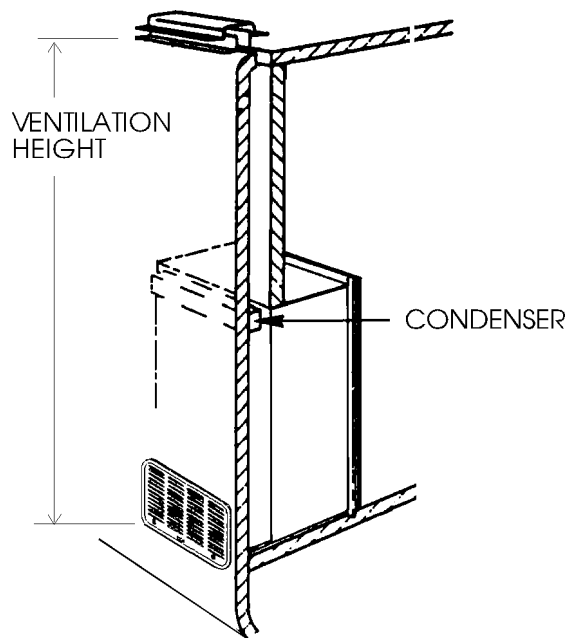

## 5. VENTILATION HEIGHTS

Refer to FIG 1., Page 2

Installation with roof vent and lower side vent	Minimum Ventilation heights in:	
REFRIGERATOR	INCHES	MM
RM2612	54	1372
RM2812	60	1524

### LOWER VENT CUTOUT



### UPPER VENT CUTOUT

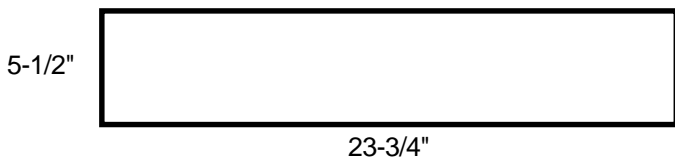

**NOTE:** All cutout dimensions are +/- 1/8".

## 6. CLEARANCES

Minimum clearances in inches to combustible materials are:

<b>G:</b> Top	0"
<b>K:</b> Side	0"
<b>L:</b> Bottom	0"
<b>M:</b> Rear	0"
<b>N:</b>	See NOTE

**NOTE:** Clearance "M" is between the rearmost part of the refrigerator and the wall behind the refrigerator.

**NOTE:** Clearance "N" is the distance between the bottom of the lower vent to the roof material. For ventilation height, refer to *Section A. Installation, Item 5. Ventilation Heights*. See FIG. 2.

FIG. 2

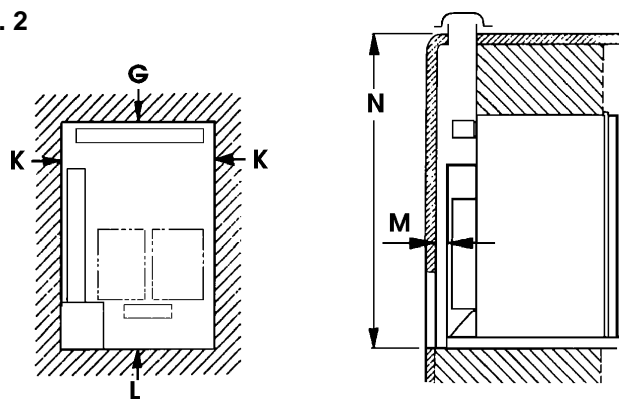
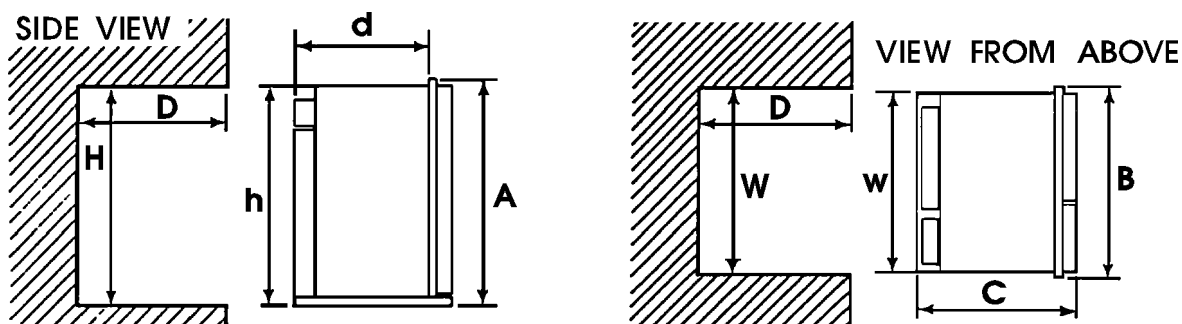

FIG. 3



Refrigerator Model	Overall Dimensions			Installation Dimensions			Recess Dimensions		
	Height A	Width B	Depth C	Height h	Width w	Depth d	Height H	Width W	Depth D
RM2612 (Inches)	51	22-23/32	24-9/16	49-7/32	21-17/32	23-19/32	49-17/32	21-13/16	24-3/32
(mm)	1295	577	624	1250	547	599	1258	544	612
RM2812 (Inches)	56-13/16	24-39/64	24-9/16	55-1/8	23-7/16	23-19/32	55-7/16	23-11/16	24-3/32
(mm)	1443	625	624	1400	595	599	1408	601	612

## 7. INSTALLING REFRIGERATOR IN ENCLOSURE

**NOTE:** DO NOT install the appliance directly on carpeting. Carpeting must be removed or protected by a metal or wood panel beneath the appliance, which extends at least the full width and depth of the appliance.

**INSTALLATION:** The refrigerator must be installed in a substantial enclosure and must be level. When installing the refrigerator in the enclosure, be certain there is a complete seal between the front frame of the refrigerator and the top, sides and bottom of enclosure. A length of sealing strip is applied to the rear surface of the front frame for this purpose. Also apply a sealing strip to the foremost floor of the enclosure and apply a second sealing strip to the bottom of the trim strip on the front base as shown in FIG. 4. The sealing should provide complete isolation of the appliance's combustion system from the vehicle interior. The dimensions shown in FIG. 3 will give you adequate

FIG. 4

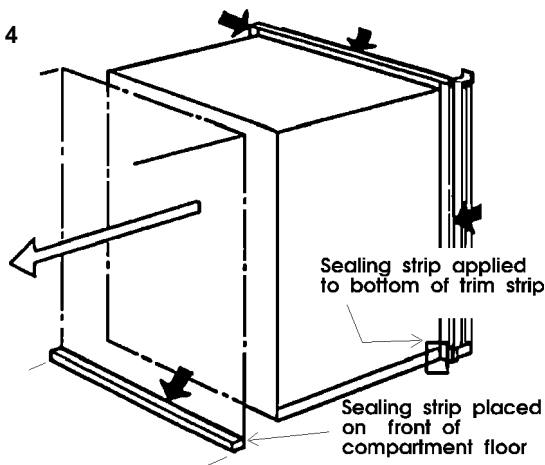

space for service and proper installation.

**NOTE:** Be careful not to damage the sealing strip applied to the floor of the enclosure when the refrigerator is put in place.

The refrigerator is secured in the enclosure with six screws and they must be installed in the following order:

- First Two Screws** installed on front base;
- Second Two Screws** installed in the top frame;
- Third Two Screws** installed in the rear base.

Failure to follow the sequence in securing refrigerator in enclosure can cause leakage between the frame and cabinet. The plastic caps are snapped in the front base to cover the screw heads and the decoration strip is secured to top frame. (See FIG. 5). Any space between the counter storage area or ceiling and top of the refrigerator should be blocked. The heat produced at the rear of the refrigerator will become trapped in this space, making the top of the refrigerator hot and reduce the efficiency of the refrigerator.

FIG. 5

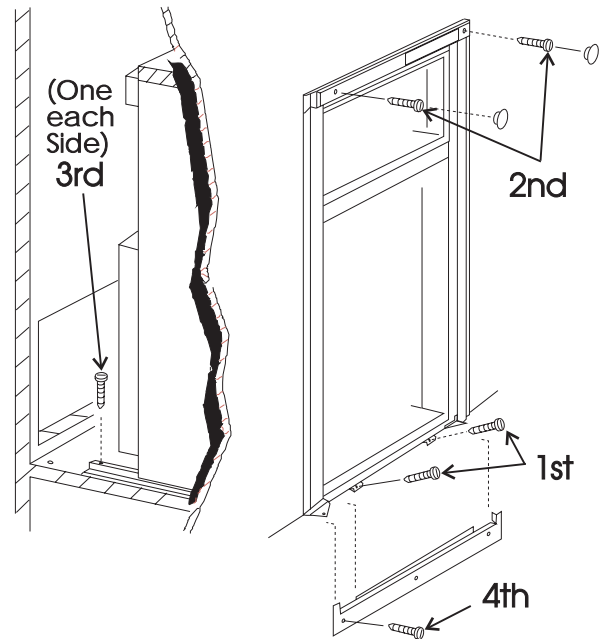

## 8. GAS CONNECTION

Hook up to the gas supply line is accomplished at the manual gas shutoff valve, which is furnished with a 3/8" SAE (UNF 5/8" - 18) male flare connection. All completed connections should be checked for leaks with an approved bubble solution. (See FIG. 6 - Gas tubing may have a different orientation than shown).

**WARNING**  
DO NOT USE A FLAME  
TO CHECK FOR GAS LEAKS.



The gas supply system must incorporate a pressure regulator to maintain a supply pressure of not more than 13-1/2 inches water column, (static) no load.

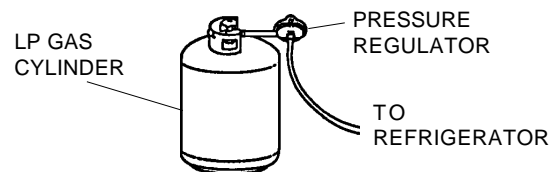

When testing the gas supply system at test pressures in excess of 1/2 psig, the refrigerator and its individual shutoff valve must be disconnected from the gas supply piping system.

When testing the gas supply system at pressures less than or equal to 1/2 psig, the appliance must be isolated from the gas supply piping by closing its individual manual shutoff valve.

In case detailed instructions on the installation and connection to the gas supply are required, contact your dealer or distributor.

FIG. 6

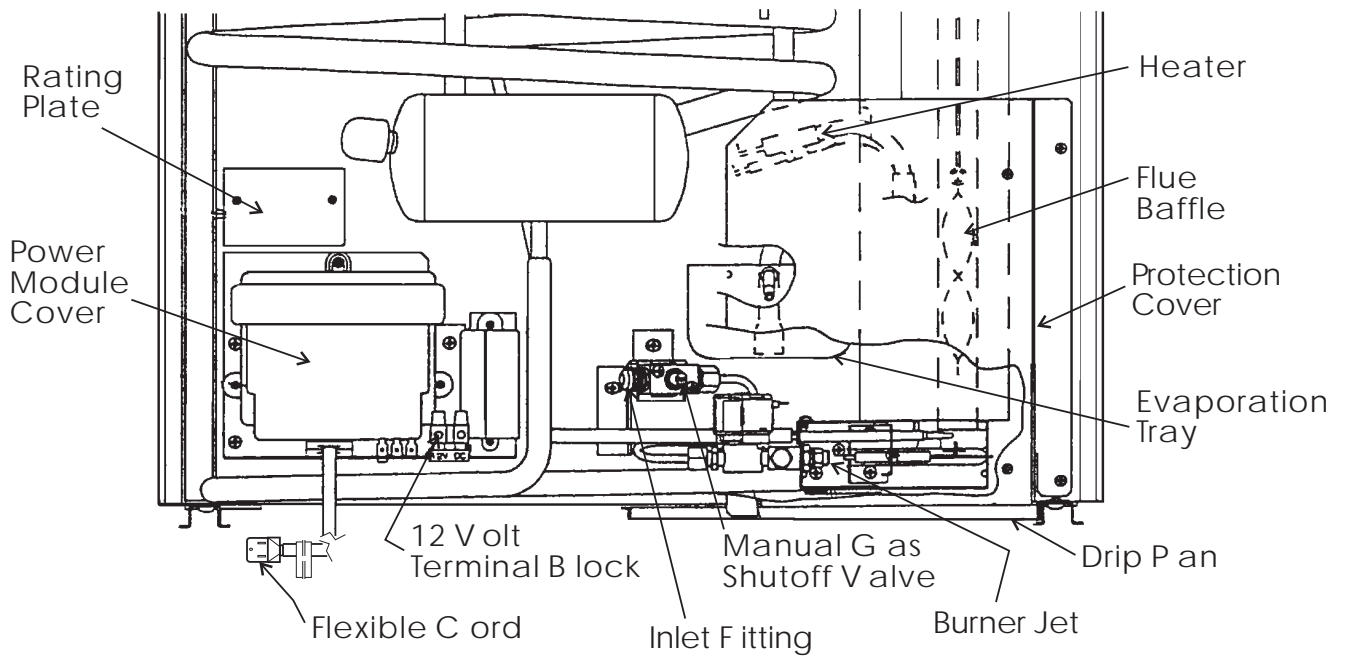

## 9. TESTING LP GAS SAFETY SHUTOFF

The gas safety shutoff must be tested after the refrigerator is connected to LP gas supply.

To test the gas safety shutoff, proceed as follows:

- Start the refrigerator according to the instructions, with 120 volts AC disconnected. See "Section C. Operation Instructions."
- Check that the gas flame is lit. In Auto mode, the Auto mode indicator lamp (A) is on. See FIG. 10.
- Close the manual shutoff valve at the back of the refrigerator. (See FIG. 6)
- Wait for one minute. The check indicator lamp (B) should now be lit and the gas flame extinguished.
- Remove cover and open the manual gas valve. Apply a noncorrosive commercial bubble solution to burner jet (see FIG. 6).
- No bubbles should appear at the opening of the burner jet. The presence of bubbles indicates a defective gas safety shutoff, and service is required.
- If no bubbles were present at the burner jet, the gas safety valve is working properly. Rinse jet thoroughly with fresh water before proceeding. Be careful not to damage burner jet. Replace cover and turn the main switch (1) OFF and back ON. (See "Section C. Operation Instructions, Item 2. Control Panel"). Normal operation of the burner should return. Allow the burner to operate for a minimum of 5 minutes.

### WARNING

**DO NOT use a flame to check for leaks.**



## 10. 120 VOLT AC ELECTRICAL CONNECTION

The refrigerator is equipped with a three-prong (grounded) plug for protection against shock hazards, and should be plugged directly into a properly grounded three-prong receptacle. DO NOT cut or remove the grounding prong from this plug. The power cord should be routed to avoid direct contact with the burner cover, flue cover or manual gas shutoff valve knob. The free length of the cord is two feet and therefore recommended that the receptacle be located to the left side of the refrigerator (viewed from the rear) and approximately six inches from the floor (see FIG. 7). This allows easy access through the vent door.

FIG. 7 120 Volt AC Receptacle

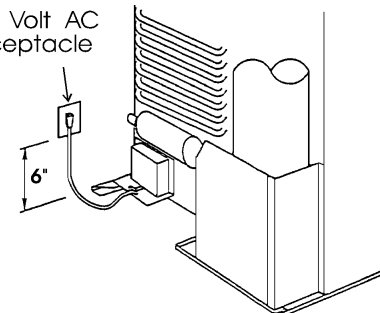

## 11. 12 VOLT DC CONNECTION

This refrigerator model requires a 12 volt DC power source to operate the automatic energy system (even though it is designed to operate on 120 volts AC and gas). The DC lead connections are at terminals located at the rear of the refrigerator. (See FIG. 6). One lead is marked positive (+) and the other negative (-). Correct polarity must be observed when connecting to the DC supply.

Do not use the chassis or vehicle frame as one of the conductors. Connect two wires at the refrigerator and route to the DC supply.

## 12. INSTRUCTION FOR MOUNTING DOOR PANEL

The refrigerator is normally delivered without the door panels. Before starting the mounting work, check that the panel dimensions are in compliance with those given in the Table on this page and the instructions are read thoroughly. When mounting the panel, proceed as follows. (See FIG. 8)

- A. On new refrigerators, the decoration strips are taped inside the door. If installed on the door, remove the door decoration strip (2) by removing its two screws (1).
- B. Insert one vertical edge into the groove of the door frame (3).
- C. Bend the panel gently so that the free side of the panel can be slipped into the corresponding groove of the door frame (4). Slide the panel down into the groove of the bottom frame (5).
- D. Between the upper edge of the panel and door frame there is a gap which should be covered by the decoration strip.
- E. Put the decoration strip across the door so that the gap is covered and push it upward (6). The tabs on the inside of the strip should fit behind the flange of the door frame. Secure the decoration strip with the two screws removed in Step A.

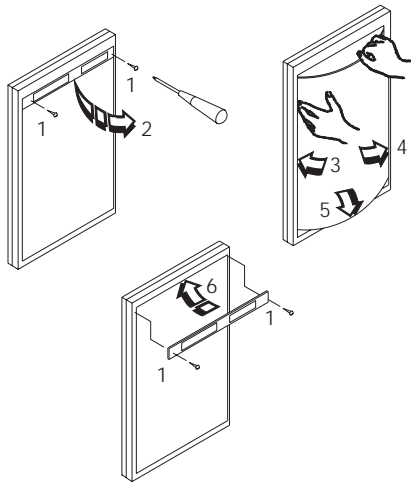

FIG. 8

PANEL DIMENSIONS					
MAX. THICKNESS 5/32" (4 mm)					
Refr. Models TYPE	HEIGHT		WIDTH		
	MAX.	MIN.	MAX.	MIN.	
<b>RM2612</b>					
upper	mm	306	304	515	513
	inch	12-3/64	11-31/32	20-9/32	20-13/64
lower	mm	819	817	515	513
	inch	32-1/4	32-5/32	20-9/32	20-13/64
<b>RM2812</b>					
upper	mm	378	376	563	561
	inch	14-7/8	14-51/64	22-11/64	22-3/32
lower	mm	897	895	563	561
	inch	35-5/16	35-15/64	22-11/16	22-3/32

## 13. CHANGING DOOR HINGES FROM ONE SIDE TO THE OTHER

Open the top door and remove the two screws holding the top decoration. The screws are accessible from beneath.

Remove the top hinge pin and lift out the door. Remove center hinge pin and lift out the lower door. Unscrew the bottom hinge pin. Remove the plastic cap from the opposite lower hinge and place it in the hole just "left empty" by the lower hinge pin. Screw the lower hinge pin in the hole from which the plastic cap was removed.

Before replacing the doors on the refrigerator, remove the catches and move them to the opposite side of the cabinet. Plastic caps for the empty holes are in the parts bag. Remount the doors and the hinge pins in the reverse order of their removal. Unscrew the handles and refasten them on the opposite side of the door. Insert the plastic caps (from the parts bag) into the holes left open on the doors. Before the top decoration is refitted, check that the door closes easily and the gasket seals well on all sides.

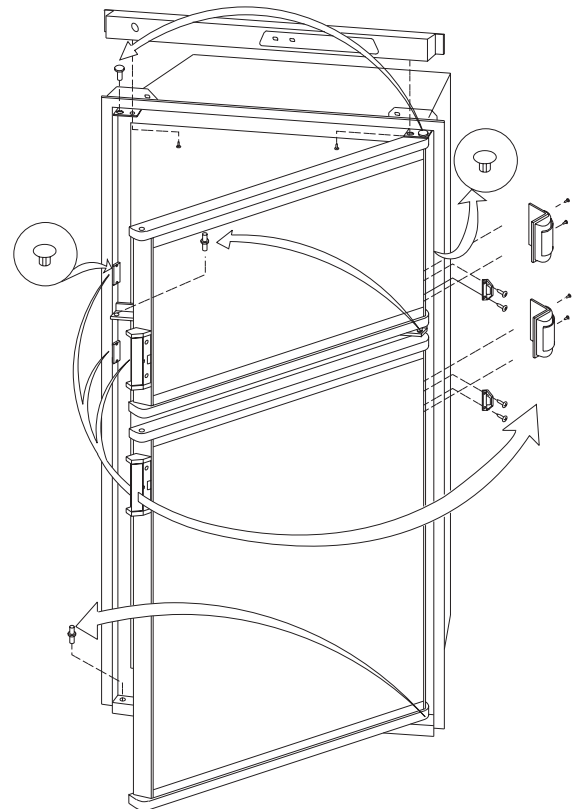

FIG. 9

## **SECTION B. CERTIFIED VENT SYSTEM KITS**

REFRIGERATOR MODEL	KIT NO.	COMPONENTS	PART NO.
RM2612 RM2812	4A	ROOF BASE ROOF COVER LOWER SIDE VENT	3103633.XXX * 3103634.XXX * 3102277.XXX *
	POWER VENT (Island/through floor)	POWER VENT ASM. ROOF BASE ROOF COVER	3104131.002 ** 3103633.XXX * 3103634.XXX *
<p>* Fill in "XXX" with color code numbers. For color codes, contact your supplier.  ** Alternate instructions forwarded with the Vent Kit.</p>			

## **SECTION C. OPERATING INSTRUCTIONS**

### **1. IMPORTANCE OF LEVELING A REFRIGERATOR**

In an absorption refrigerator system, ammonia is liquefied in the finned condenser coil at the top of the refrigerator. The liquid ammonia then flows into the evaporator (inside the freezer section) and is exposed to a circulating flow of hydrogen gas, which causes the ammonia to evaporate, creating a cold condition in the freezer.

The tubing in the evaporator section is specifically sloped to provide a continuous movement of liquid ammonia downward by gravity through this section. If the refrigerator is operated when it is not level and the vehicle is not moving, liquid ammonia will accumulate in sections of the evaporator tubing. This will slow the circulation of hydrogen and ammonia gas, or in severe cases, completely block it, resulting in a loss of cooling.

Any time the vehicle is parked for several hours with the refrigerator operating, the vehicle should be leveled to prevent this loss of cooling. The vehicle needs to be leveled only so it is comfortable to live in (no noticeable sloping of floors or walls).

When the vehicle is moving, the leveling is not critical as the rolling and pitching motion of the vehicle will pass to either side of level, keeping the liquid ammonia from accumulating in the evaporator tubing.

## 2. CONTROL PANEL

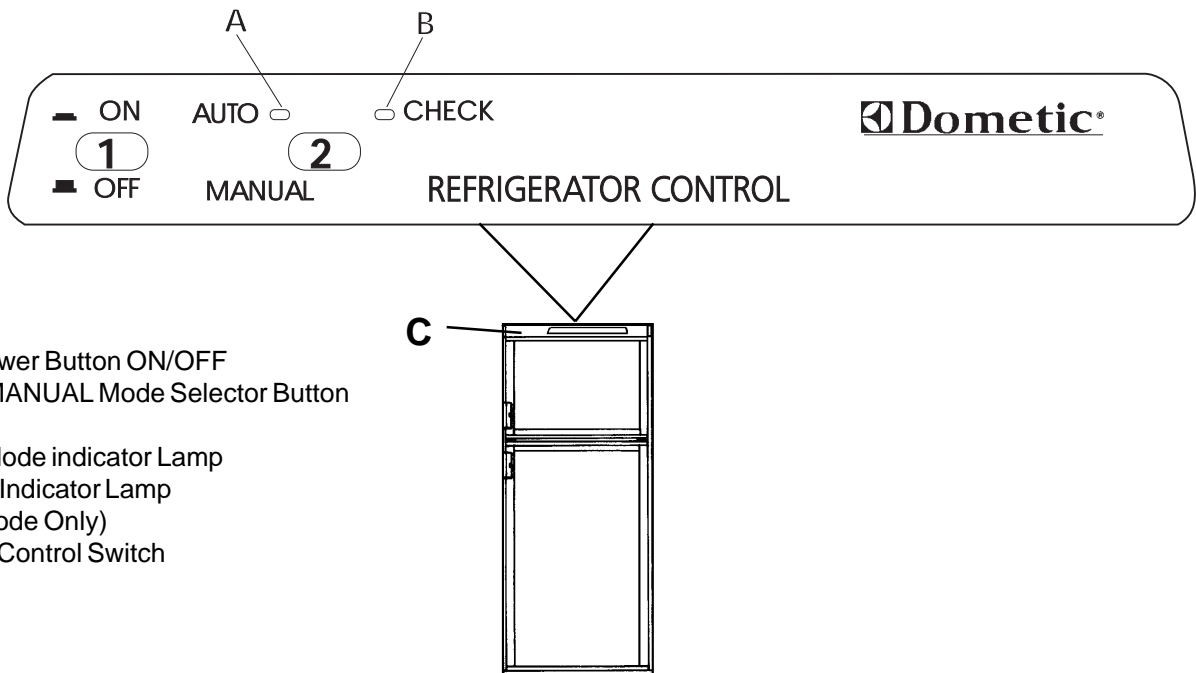

### LEGEND

1. Main Power Button ON/OFF
  2. AUTO/MANUAL Mode Selector Button
- A. AUTO Mode indicator Lamp  
B. CHECK Indicator Lamp  
(GAS Mode Only)  
C. Climate Control Switch

## 3. OPERATING INSTRUCTIONS

### A) START-UP INSTRUCTIONS

- 1) 12 volt DC supply must be available for the electronic control to function.
- 2) Press the main power ON/OFF button (1) to the DOWN position.
- 3) In AUTO mode operation, the temperature is controlled by a single temperature setting, on the energy source selected by the control system. (See Sec. B)
- 4) In MANUAL mode operation, the refrigerator will run continuously on the energy source selected by the control system. (See Sec. C)

NOTE: The food in the lower compartment may be frozen if the refrigerator is left on in the MANUAL mode.

### B) AUTOMODE

- 1) Press the AUTO/MANUAL mode selector button (2) to the DOWN position. The AUTO mode indicator lamp (A) will illuminate.
- 2) When operating in the AUTO mode, the AUTO mode indicator lamp (A) will illuminate. The control system will automatically select between AC and GAS operation with AC having priority over GAS. If the control system is operating with AC energy and it then becomes unavailable, the system will automatically switch to GAS. As soon as AC becomes available again the control will switch back to AC operation.
- 3) If 120 volts AC is not available, the control system will automatically switch to GAS operation. Within 45 seconds the burner should be ignited and operating normally. If unsuccessful, the CHECK indicator lamp (B) will illuminate.  
To restart an ignition attempt with the CHECK lamp illuminated or to clear (turn off) the CHECK lamp, press the main power ON/OFF button to the OFF and

then ON position. The control system will attempt a new 45 second ignition sequence.

- 4) On the initial refrigerator start-up on gas (120 volts AC is not available), it may take longer than 45 seconds to allow air to be purged from the gas line. If the refrigerator has not been used for a long time or the LP tanks have just been refilled, air may be trapped in the supply lines. To purge the air from the lines may require resetting the main power ON/OFF button (1) three or four times. If repeated attempts fail to start the LP gas operation, check to make sure that the LP gas supply tanks are not empty and all manual shutoff valves in the lines are open. If the problem is still not corrected, contact a service center for assistance.

NOTE: Do not continue to reset GAS operation if the CHECK indicator lamp continues to be illuminated after several tries.

- 5) If 120 volts AC becomes available while the CHECK indicator lamp is on, the control system will switch to 120 volt AC operation. The CHECK lamp will not turn off until the main power ON/OFF button is pressed to the OFF then ON position.
- 6) In AUTO mode operation, the temperature is controlled by a single temperature setting.

### C) MANUAL MODE

- 1) When operating in the MANUAL mode, the AUTO mode indicator lamp (A) will be off, and the refrigerator will run continuously on the energy source selected by the control system.
- 2) The control system will automatically select between AC and GAS operation with AC having priority over GAS. If the control system is operating with AC energy and it then becomes unavailable, the system



will automatically switch to GAS. As soon as AC becomes available again, the control will switch back to AC operation.

- 3) If the CHECK indicator lamp (B) illuminates, the control has failed to ignite the burner on GAS. To reset when the CHECK indicator lamp (B) is illuminated, press the main power ON/OFF button (1) to the OFF and then ON position.
- 4) The difference from AUTO mode is that in MANUAL mode operation, the refrigerator will run without thermostat control on the energy source selected by the control system.

NOTE: The food in the lower compartment may be frozen if the refrigerator is left on in the MANUAL mode.

#### D. STANDBY MODE OF OPERATION

This control system contains a feature that will continue to operate the cooling system in the event of a failure of a major operating component. If the control cannot read the temperature sensor and operate at the preset temperature, then the control will run the cooling unit continuously at the energy source available. It operates like the MANUAL mode.

The refrigerator will continue to operate in this mode indefinitely or until a new sensor is installed and the system is reset.

#### E. TO SHUT OFF THE REFRIGERATOR

The refrigerator may be shut off while in any mode of operation by pressing the main power ON/OFF button to the UP (OFF) position.

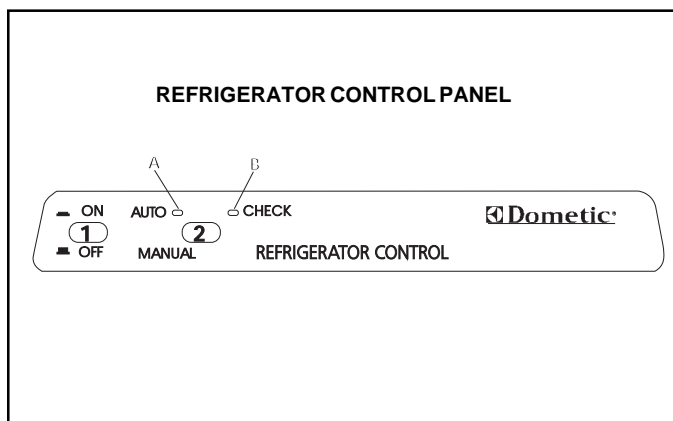

## 4. HOW TO USE THE REFRIGERATOR

### A. FOOD STORAGE COMPARTMENT

The food storage compartment is completely closed and unventilated, which is necessary to maintain the required low temperature for food storage. Consequently, foods having a strong odor or those that absorb odors easily should be covered. Vegetables, salads, etc. should be covered to retain their crispness. The coldest positions in the refrigerator are under the cooling fins and at the bottom of the refrigerator. The warmer areas are on the upper door shelves.

This should be considered when placing different types of food in the refrigerator.

### B. FROZEN FOOD STORAGE COMPARTMENT

Quick frozen soft fruits and ice cream should be placed in the coldest part of the compartment which is on or just below the freezer shelf. Frozen vegetables, may be stored in any part of the compartment.

This compartment is not designed for deep or quick freezing of food. Meat or fish, whether raw or prepared, can be stored in the frozen food storage compartment provided they are precooled first in the refrigerator. They can be stored about three times longer in the frozen food compartment as compared to the fresh food compartment. To prevent food from drying out, keep it in covered dishes, containers, plastic bags or wrapped in aluminum foil.

### C. ICE MAKING

Ice cubes can be made in the ice tray placed in the freezer compartment. The tray should be filled with water to within 1/4" (5mm) from the top. For faster ice making, the tray should be placed in direct contact with the freezer shelf.

To release the ice cubes, seize the tray with both hands and twist the tray. Cubes not required should be replaced in the tray. Refill the tray with water and replace the tray on the freezer shelf.

Ice will be made more rapidly if the thermostat is set at its highest position. It is a good idea to do this a few hours before the anticipated need for ice, but be sure to move the thermostat back to normal setting, usually about mid-setting when the ice is formed. Food in the lower compartment may be frozen if the setting is left on "MANUAL" position.

### C. DEFROSTING

Shut off the refrigerator by pressing the main power ON/OFF button to the UP (OFF) position. Empty the refrigerator, leaving the drip tray under the finned evaporator, and the cabinet and freezer doors open. Defrosting time can be reduced by filling the ice tray with hot water and placing it on the freezer shelf.

### CAUTION

**DO NOT** use a hot air blower. Permanent damage could result from warping the metal or plastic parts. **DO NOT** use a knife or an ice pick, or other sharp tools to remove frost from the freezer shelf. They can create a leak in the ammonia system.

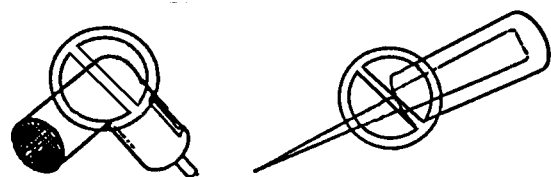

When all frost is melted, dry the interior of the refrigerator with a clean cloth. Replace all food and start the refrigerator by pressing the ON/OFF button (1) to DOWN position.

NOTE: On these models the drip tray/cup is on the rear side of the refrigerator. (See FIG. 1)

Put the plastic drain tube in a watertight bucket or container (access through louvered service panel on the outside of the vehicle). As the frost melts, the water will flow into the container. When all the frost has melted wipe up the excess moisture and empty the accumulated water from the bucket. Replace the drain tube to its original position.

#### E. CLEANING

Cleaning the refrigerator is usually done after it is defrosted or put into storage. To clean the interior liner of the refrigerator, use lukewarm weak soda solution. Use only warm water to clean the finned evaporator, ice trays and shelves. NEVER use strong chemicals or abrasives to clean these parts as the protective surfaces will be damaged. It is important to always keep the refrigerator clean.

#### F. SHUT-OFF (STORAGE PROCEDURE)

Shut off the refrigerator by pressing the main power ON/OFF button to the UP (OFF) position.

If the refrigerator will not be in operation for a period of weeks, it should be emptied, defrosted, cleaned and the doors left ajar. The ice tray should also be dried and kept outside the cabinet.

#### G. CLIMATE CONTROL

During the summer months of high temperatures and humidity, the metal frame between the freezer and fresh food compartments may have water droplets forming. The number of water droplets will increase if the vehicle isn't air conditioned during these months.

This refrigerator comes standard with a 12 volt (DC) climate control that will evaporate the water droplets when they form.

To have this climate control on, you position the switch (See "C", Fig. 10) located beneath the top decorative strip that houses the control panel to ON. The climate control can be left on continuously or only used when temperatures require it.

NOTE: The climate control will draw 12 volts DC power continuously when in the ON position. It should be turned OFF when a charging source is not available.

### **! WARNING**

**Most LP gas appliances used in recreational vehicles are vented to the outside of the vehicle. When parked close to a gasoline pump, it is possible that the gasoline fumes could enter this type of appliance and ignite from the burner flame, CAUSING A FIRE OR AN EXPLOSION.**

**FOR YOUR SAFETY, when refueling, shut off all LP gas appliances which are vented to the outside.**

## **SECTION D.**

# **MAINTENANCE & SERVICE**

## **1. REFRIGERATOR REMOVAL**

Before working on the refrigerator, make sure the AC voltage and DC voltage leads are disconnected. Shut off the gas supply. Disconnect the gas supply line. Cap the gas supply line, loosen the screws anchoring the refrigerator to the enclosure and slide the refrigerator out of the compartment.

Replacement is the reverse of removal. Check all connections for gas leaks. Refer to *Section A, Item 1 to 12 of Installation Instructions*.

## **2. PERIODIC MAINTENANCE**

To keep your Dometic refrigerator operating efficiently and safely, periodic inspection and cleaning of several components once or twice a year is recommended.

A. It is important to keep the area at the back of the refrigerator clean. Check the lower vent, upper vent and area between these openings for any obstructions such as bird/insect nests, spider webs, etc. Clean the coils on the back of the refrigerator. Use a soft bristled brush to dust off the coils.

It is important to keep the refrigerator area free from combustible material, gasoline and other flammable vapors or liquids.

B. Check all connections in the LP gas system (at the back of the refrigerator) for gas leaks. The LP gas supply must be turned on. Apply a noncorrosive bubble solution to all LP gas connections. The appearance of bubbles indicates a leak and should be repaired immediately by a QUALIFIED SERVICEMAN WHO IS FAMILIAR WITH LP GAS SYSTEMS AND REFRIGERATORS.

### **! WARNING**

**DO NOT USE A FLAME TO CHECK FOR GAS LEAKS.**



C. Check the control system by connecting/disconnecting 120 volt AC power. Compare the operation with the operation described in *Section C. Operation Instructions*.

NOTE: The following maintenance is required once or twice a year, but should only be done by a qualified serviceman who is familiar with LP gas systems and refrigerators.

D. The LP gas pressure should be checked and the main regulator readjusted if pressure is incorrect. The correct operating pressure is 11 inches of water column. The correct place to take the LP gas pressure is at the test port just ahead of the burner jet. (See FIG. 12).

E. Inspect the flue baffle. It should be reasonably clean and

free of soot. Heavy soot formation indicates improper functioning of the burner. The flue and burner both require cleaning in the following manner:

- 1) Unplug the refrigerator power cord from the 120 volt AC outlet (see FIG. 6).
- 2) Disconnect or shut off the 12 volt power to the refrigerator.
- 3) Turn manual shutoff valve to OFF. (See FIG. 6 & 12).
- 4) Remove cover from the burner housing. (See FIG. 6).
- 5) Disconnect the wire from the high voltage electrode.
- 6) Remove the burner mounting screws and remove the burner assembly.
- 7) Remove the flue cap from top of flue tube and lift out the wire and spiral baffle. Clean the flue from the top using a flue brush. Blowing compressed air into the flue will not properly clean soot and scale out of the flue tube. Replace spiral baffle and flue cap.
- 8) Clean burner tube with a brush. Blow out burner with compressed air.
- 9) Before removing burner jet, clean burner area of soot and scale that fell out of flue tube. Remove the burner jet. Soak the jet in wood alcohol and allow it to air dry. Reinstall and tighten burner jet.

**! WARNING**

**DO NOT use a wire or pin when cleaning the burner jet as damage can occur to the precision opening. This can cause damage to the refrigerator or create a fire hazard.**

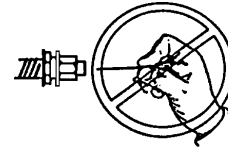

- 10) Reinstall burner, being careful that the end of the burner fits into the slot on the burner bracket. Check to make sure slots are centered under the flue tube and the thermocouple is positioned properly (tip of thermocouple extends over two slots of burner).
- 11) Be sure to reconnect the wire to high voltage electrode. Check the electrode for proper location and gap. (See FIG. 11).

**FIG. 11**

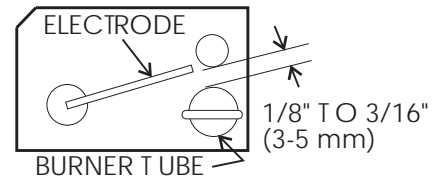

- 12) Turn on manual gas shutoff valve and check all fittings for leaks.
- 13) Connect 120 volt power cord to the outlet and reconnect or turn on the 12 volt DC power.
- 14) Check LP gas safety shutoff. See *Section A. Installation, Item 9. Testing LP Gas Safety Shutoff.*

**GAS EQUIPMENT ASSEMBLY**

**FIG. 12**

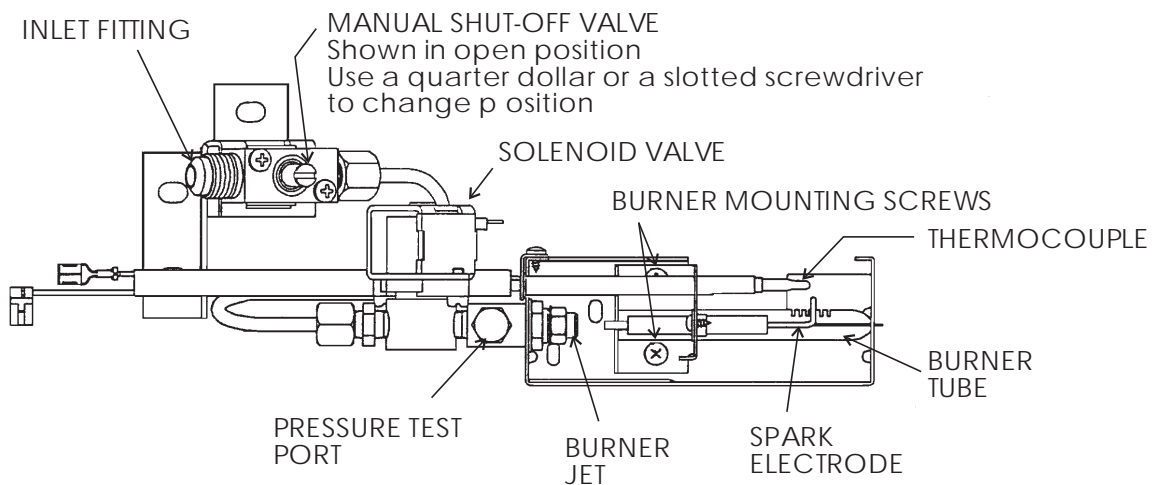

## F. FUSES

The refrigerator is equipped with 2 fuses, one for the refrigerator control system and one for the AC cartridge heater. (See Table below).

To replace fuse(s) proceed as follows:

1. Disconnect the wall plug, and the 12 volt wires.
2. Remove the power module cover. See FIG. 6.
3. Snap the fuse out of the fuse holder.
4. Fit a new fuse in to the fuse holder.
5. Replace the power module cover.

Control System	3-amp
AC Heater	5-amp

## 3. TROUBLESHOOTING

### Refrigerator Does Not Cool Properly

- Burner jet clogged.**  
Clean. See *Section D. Maintenance & Service, Item 1. Periodic Maintenance, Paragraph E. Item 19.*
- Check level of refrigerator.**
- Venting problem.**  
Restriction in air flow across cooling unit.
- Heavy frost buildup on evaporator fins.**  
Defrost.

E. Flue baffle not inserted properly in flue tube.

F. Improperly set thermostat.

See *Section C. Operating Instructions, Item 3. Paragraph F, and Item 4, Paragraph H.*

G. Burner dirty.

Clean. See *Section D. Maintenance & Service, Item 1. Periodic Maintenance, Paragraph E.8.*

H. LP gas pressure low at burner.

Set main regulator so pressure does not drop below 11 inches water column at pressure tap.

I. Burner not located properly under flue tube.

Relocate.

J. Burner damaged.

Replace.

K. Odors and fumes.

1. Dislocated burner
2. Damaged burner
3. Dirty flue tube

L. FUSES

1. Refrigerator AC Supply
2. Refrigerator DC Supply
3. Control system. See *Section D. Maintenance & Service, Item 2. Paragraph F.*

**Contact an authorized service center for parts and repairs as needed.**

## WIRING DIAGRAM

