



**FILTER & FAUCET
INSTALLATION GUIDE**

Installation Documentation and Sign-Off

Filter Model: _____ Faucet Model: _____

Installation Date: _____ Plant #: _____

RV Model Type: _____ Serial #: _____

Installed By: _____

Inspected By: _____ Date: _____

Final Test By: _____ Date: _____

Pre-Inspection

- | | | |
|--|--|--|
| <p>Filter</p> <ul style="list-style-type: none"> <input type="checkbox"/> O-Ring O.K. <input type="checkbox"/> No Cracks <input type="checkbox"/> Filter Clip O.K. <input type="checkbox"/> Filter Accessible <input type="checkbox"/> Free Tubing Run | <p>Tubing</p> <ul style="list-style-type: none"> <input type="checkbox"/> No Scratches <input type="checkbox"/> Length O.K. <input type="checkbox"/> Square Cut Ends <input type="checkbox"/> No Burrs <input type="checkbox"/> No Kinks | <p>Faucet</p> <ul style="list-style-type: none"> <input type="checkbox"/> Fitting O.K. <input type="checkbox"/> Finish O.K. <input type="checkbox"/> Hardware O.K. |
|--|--|--|

Installation

- Faucet**
- Clean Area
 - Proper Order
gasket-counter-washer-nut
 - Alignment O.K.
 - Tightened Properly

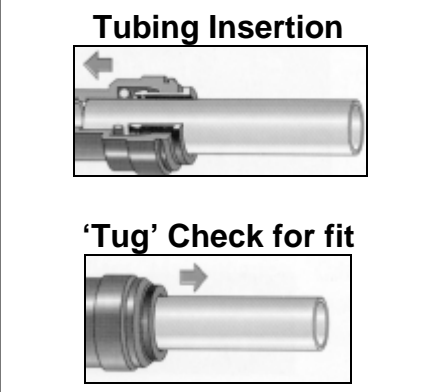

- Filter**
- No Kinks or Twists
 - Flow Arrow O.K.
 - Tubing Inserted
 - Tube Bottom Out
 - Pull Test O.K.
 - Install In Clip O.K.

System Test

- Air Test ____PSI
- Water Test ____PSI
- Filter Test O.K.
- Faucet Test O.K.
- By-Pass Test O.K.
(if used)

Installation & Test Notes:

Faucet or filter failure disposition:



Installation Instructions

Model Series RV-6FJG, RV-10FJG, 94-009-4x

This filter may be installed in any convenient location. Be sure to keep filter away from any heat source. Waterguard in-line filters are great for RV, marine and home applications.

Filter Installation

1. Shut off water supply.
2. Disconnect existing filter or cut water line where filter is to be installed.
3. Be sure flow direction is correct.
To connect tubing: push tubing into appropriate inlet/outlet end of filter. Make sure tubing goes past o-ring and bottoms out. Tubing will move back slightly and lock in place.
To remove tubing: push tubing back to bottom out position, hold collet ring tightly against filter and pull tubing. Repeat above procedure if drip leak occurs, inspecting tubing for scratches. **If tubing has scratches, cut off scratched portion of tube.**
4. Turn water on and allow 5 gallons of water to flow into a bucket or other receptacle until clear. Turn off water. Connect outlet water line to filter as in step 3 above. Turn on water slowly and check for leaks.
5. Check filter after several hours for slight leaks not visible during initial installation.

Operating Instructions

All filters should be replaced seasonally (6-12 months) or when taste and odor problems return.

Winterizing or Changing Filter

Turn off pump, relieve pressure, drain system, and either: a) close shut-off valve (if equipped) and disconnect filter, or b) disconnect filter and install by-pass fitting. Discard old filter.

Note: Some state and local laws and regulations may pertain to the installation of any plumbed-in components. Check for compliance in your area.

Model	Diameter x Length	Capacity	Class
RV-6	2" x 6" [51mm x 152mm]	1,950 gallons [7,300 liters]	I
RV-10	2" x 10" [51mm x 254mm]	3,900 gallons [14,700 liters]	I
RV-210	2.5" x 11" [63.5mm x 279mm]	6,000 gallons [22,700 liters]	I



Tested and certified by NSF International against ANSI/NSF Standard 42 for the Reduction of Taste and Odor and Chlorine, Class I

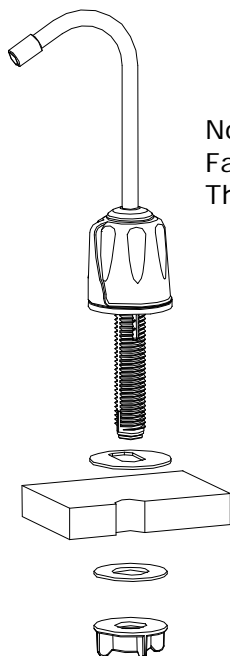

Faucet Installation

Notes:
Faucet base = 2" dia.
Thread length = 3-1/2"

1. Drill 3/4 inch hole through counter.
2. Slide faucet thru gasket, counter, and washer.
3. Align faucet and hand-tighten nut.
4. Attach tubing to faucet inlet.
5. Turn on water.
6. Check for leaks.



*ISO Certified Facility



SHURflo reserves the right to update specifications, prices, or make substitutions.

SHURflo ★
5900 Katella Ave.
Cypress, CA 90630
(800) 854-3218 (562) 795-5200
FAX (562) 795-7564

SHURflo East
52748 Park Six Court
Elkhart, IN 46514-5427
(800) 762-8094
(574) 262-0478
FAX (574) 264-2169
© 2004 All Rights Reserved

SHURflo Ltd.
Unit 5 Sterling Park
Gatwick Road, Crawley
West Sussex, RH10 2QT
United Kingdom
+44 1293 424000
FAX +44 1293 421880