



CAREFREE OMEGA II AWNING OWNERS MANUAL / INSTRUCTIONS

CUSTOMER MUST RECEIVE THIS MANUAL UPON INSTALLATION—MANUAL CONTAINS SAFETY, INSTALLATION, OPERATION, CARE AND MAINTENANCE AND WARRANTY INFORMATION

IMPORTANT NOTE: READ ENTIRE INSTRUCTIONS BEFORE BEGINNING INSTALLATION. FOLLOW ALL CAUTIONS, WARNINGS AND NOTES TO PREVENT INJURY OR DAMAGE TO AWNING OR VEHICLE. WARRANTY BENEFITS DO NOT APPLY TO IMPROPERLY INSTALLED OMEGA II AWNINGS.

TOOLS AND SUPPLIES REQUIRED

Drill
1/8" & 7/32" Drill Bits
PUTTY TAPE OR SILICONE SEALER
1/4" & 5/16" SOCKET OR WRENCH

SECTION I: SAFETY

CAUTION: Means a hazard that may cause minor or moderate injury if the warning is ignored. It also may mean a hazard that will cause damage to property.

CAUTION: RAIL MUST BE MOUNTED SUCH THAT IT DOES NOT INTERFERE WITH THE SLIDEOUT CLOSING AND SEALING WHEN IT IS IN THE COMPLETE RETRACTED POSITION.

CAUTION: THE COTTER PINS ARE HOLDING THE PRE-WOUND TENSION ON THE ROLLER ASSEMBLY. CARE MUST BE TAKEN TO PREVENT ANY DAMAGE OR INJURY WHEN REMOVING THESE PINS.

CAUTION: DO NOT RELEASE STRAP UNTIL THE AWNING IS AGAINST THE SLIDEOUT FACE. THIS SPRING RETURN WILL RAPIDLY ROLL UP AWNING RESULTING IN A SLAM AGAINST THE SLIDEOUT FACE, POSSIBLY DAMAGING THE RV OR AWNING!

SECTION II: SPECIFICATIONS

IMPORTANT NOTE: BEFORE BEGINNING THE INSTALLATION, BE SURE TO READ THE INFORMATION BELOW TO ENSURE THAT THE OMEGA AWNING IS THE CORRECT SIZE!

GENERAL SPECIFICATIONS

- *Omega Awnings are custom made for the length and extension of the slideout room. The actual canopy of the Omega Awning will measure approximately 4" longer than the "B" dimension on the order form.*
- *Arm mounting brackets must mount on a flat surface that is a minimum of 1-1/6" wide.*

AWNING RAIL SPECIFICATIONS

- *Rail can be mounted with the slot (where fabric slides in) facing up or with the slot facing down.*
- *Rail must mount on to a straight, flat, solid mounting surface.*
- *Rail must be mounted to where the slot of the rail is positioned a minimum of 1" above the face of the slideout.*

CAUTION: RAIL MUST BE MOUNTED SUCH THAT IT DOES NOT INTERFERE WITH THE SLIDEOUT CLOSING AND SEALING WHEN IT IS IN THE COMPLETE RETRACTED POSITION.

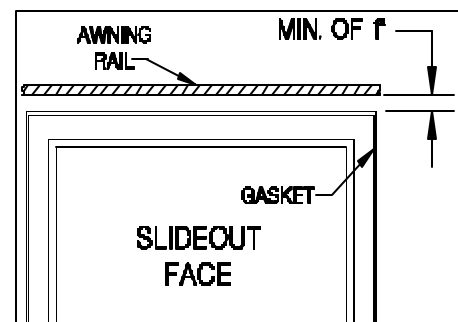

SECTION III:

OMEGA INSTALLATION

1

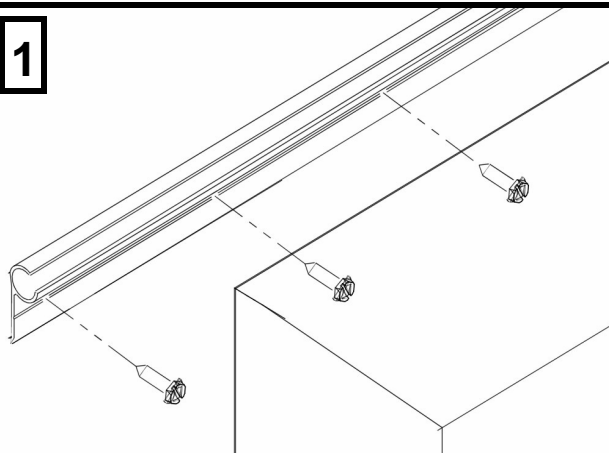

Apply Putty Tape behind awning rail and install rail in the position described on the previous page using the #10 x 3/4" Hex Head Screws provided

2

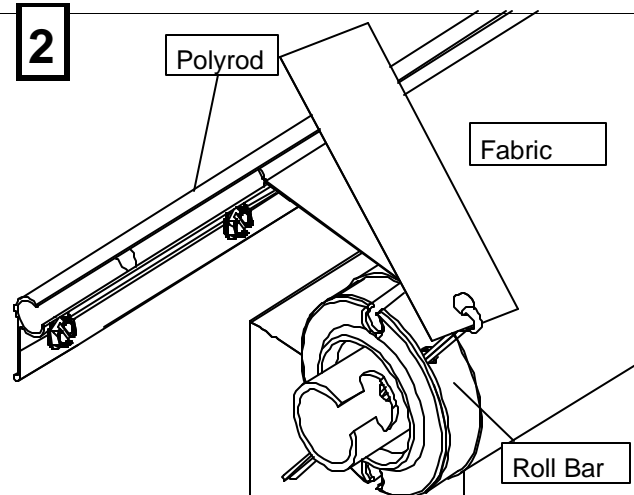

Extend room approximately 8". Insert Polyrod And Fabric Into Awning Rail. Carefully slide the awning into the rail and center on rail.

3

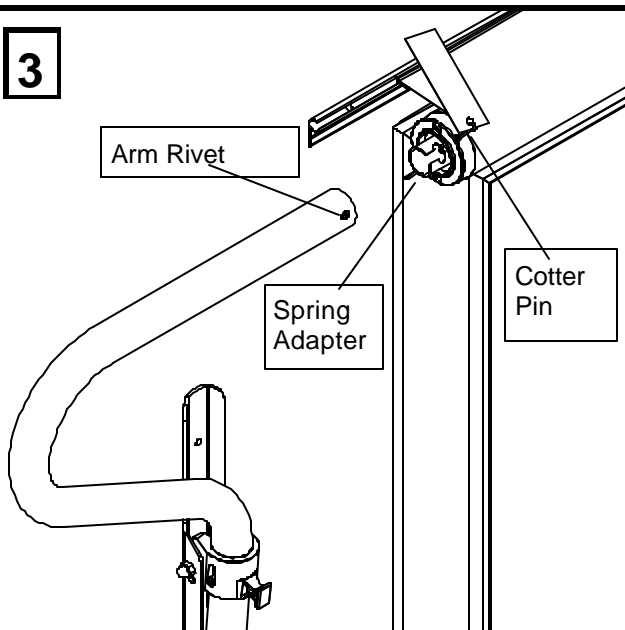

A. Slide the left arm over the spring adapter and engage the rivet inside the arm into the slot of the spring adaptor. Rotate arm until arm rivet catches into place into the adapter.

B. While holding on to the arm, **CAREFULLY PULL THE COTTER PIN OUT.** **CAUTION: THE COTTER PIN IS HOLDING THE PRE-WOUND TENSION ON THE ROLLER ASSEMBLY. CARE MUST BE TAKEN WHEN REMOVING THE PIN.** Push the arm into the roller tube.

4

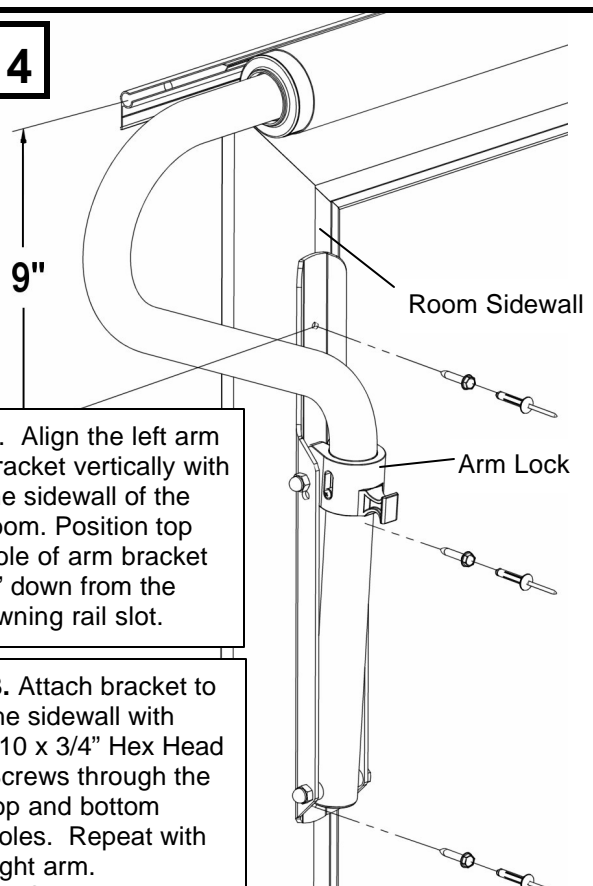

A. Align the left arm bracket vertically with the sidewall of the room. Position top hole of arm bracket 9" down from the awning rail slot.

B. Attach bracket to the sidewall with #10 x 3/4" Hex Head Screws through the top and bottom holes. Repeat with right arm.

C. Slide arm lock up and pull awning outward to attach at center holes.

Note: You can also drill 7/64" holes and use the 3/16" Molly Rivets for attaching brackets.

SECTION III: OMEGA INSTALLATION (cont.)

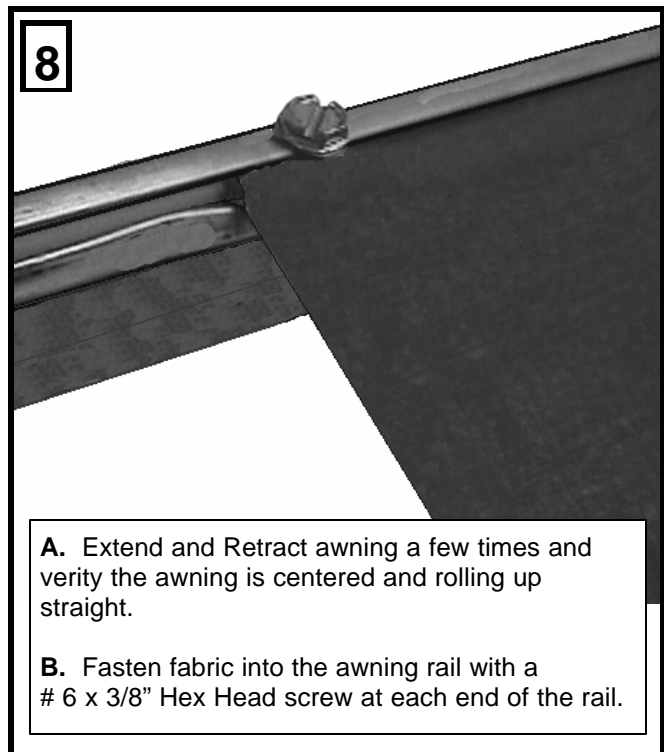
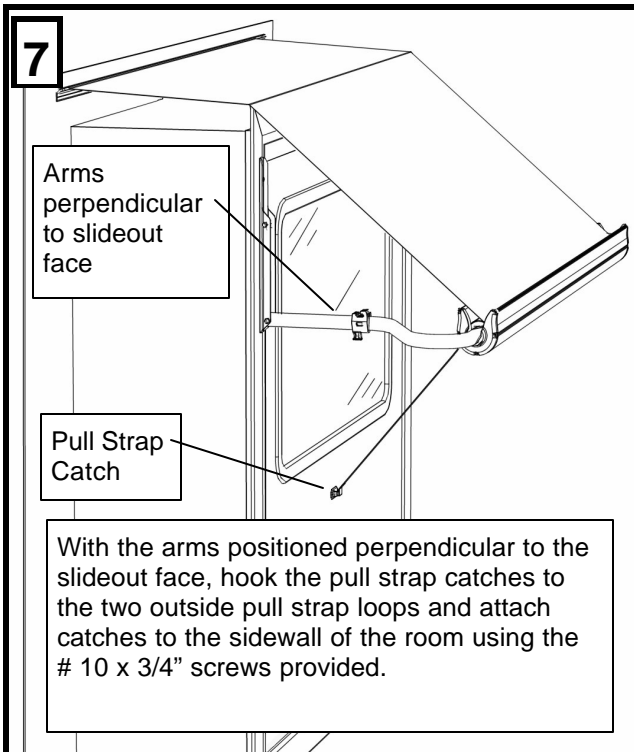
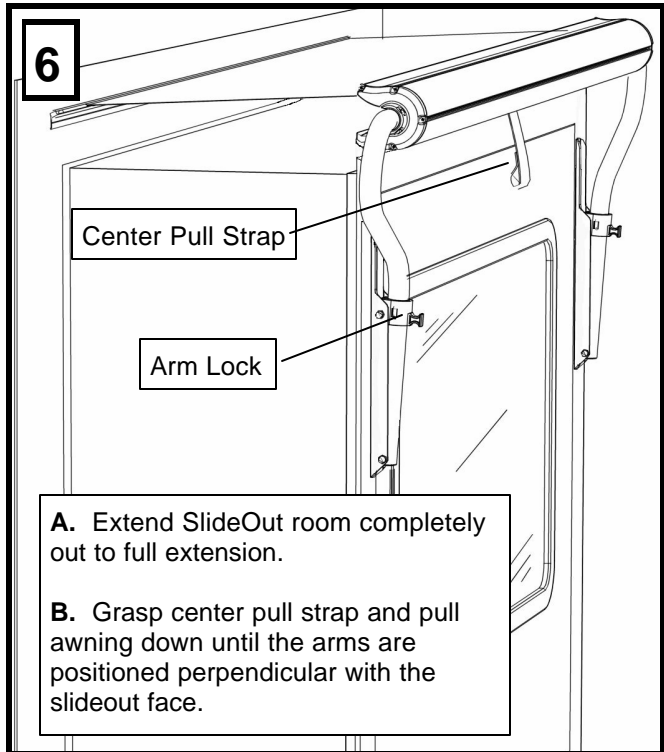
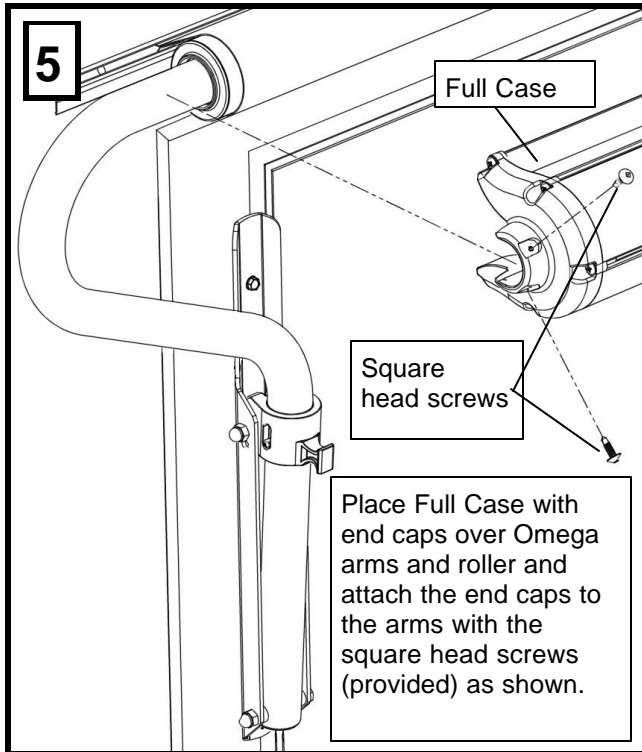

SECTION IV:

OMEGA OPERATION

TO EXTEND OMEGA:

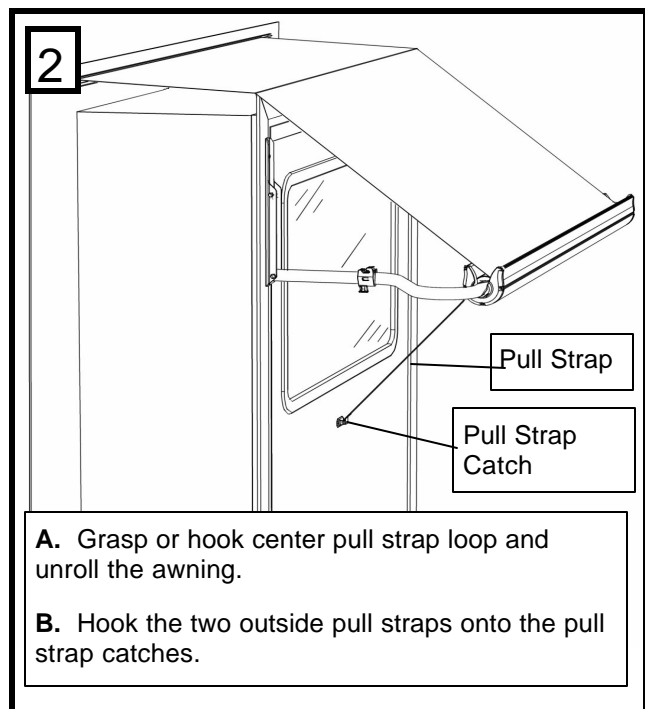
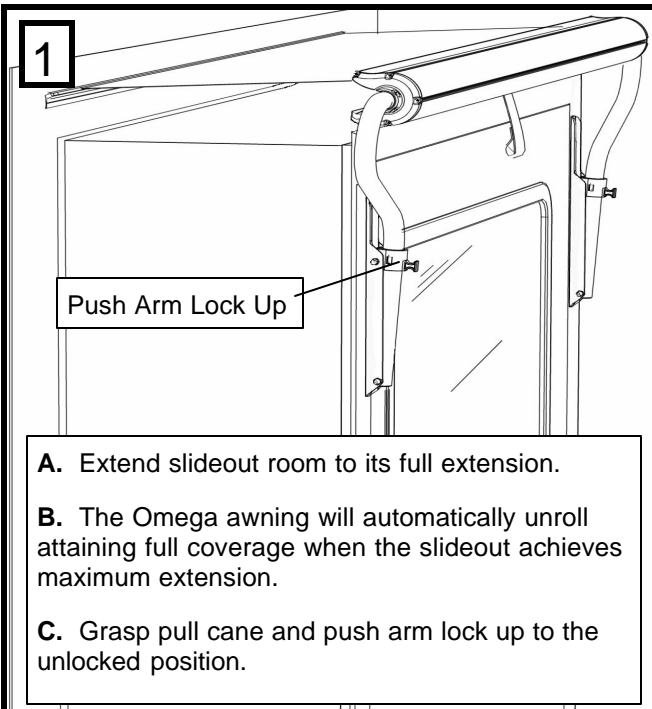

TO RETRACT OMEGA:

A. Remove loops of pull straps from catches and grasp center pull strap allowing awning to roll up to its stored position against the slideout face. **CAUTION: DO NOT RELEASE STRAP UNTIL THE AWNING IS AGAINST THE SLIDEOUT FACE. THE SPRING RETURN WILL RAPIDLY ROLL UP THE AWNING RESULTING IN A SLAM AGAINST THE SLIDOUT FACE, POSSIBLY DAMAGING THE RV OR AWNING!**

B. Grasp pull cane and pull arm locks down to the locked position. Retract slideout to the complete closed position. **NOTE: WHEN RETRACTING SLIDEOUT IT IS A GOOD IDEA TO STOP THE ROOM HALFWAY IN TO ENSURE FABRIC IS ROLLING PROPERLY BEFORE CONTINUING RETRACTION!**

WATERPOOLING

UNDER CERTAIN CONDITIONS, WATER MAY POOL ON THE TOP OF THE EXTENDED OMEGA. IF WATER IS ALLOWED TO POOL ON THE FABRIC FOR A LONG PERIOD OF TIME, IT MAY CAUSE THE FABRIC TO STRETCH. **THIS IS NOT COVERED UNDER WARRANTY!** TO PREVENT THE FABRIC FROM STRETCHING IF SUBJECTED TO WATER POOLING, PERIODICALLY RETRACT THE ROOM THUS ALLOWING THE WATER TO AUTOMATICALLY DUMP OFF OF THE FABRIC AS THE ROOM GOES IN.

FOR CLEANING INSTRUCTIONS SEE NEXT PAGE

SECTION V:

CARE AND MAINTENANCE

CLEANING: VINYL: Mildew will not form on the awning material itself, but may form on the dust allowed to accumulate on the canopy. A quality vinyl cleaner or mild soap and water will keep your awning looking new. Once cleaned make sure the awning is rinsed thoroughly and is dried before storing. **DO NOT USE BLEACH!**

CLEANING: ACRYLIC: Mild soap and water should be used to clean the acrylic canopy.

A stiff brush may be necessary to help when removing tough stains. Once cleaned, use plenty of clean water to completely rinse fabric clean. **CAUTION: DO NOT USE CAUSTIC CLEANERS, MILDEW REMOVERS OR METAL CLEANERS ON FABRIC AS THEY CAN DESTROY COLORS AND WILL NOT BE COVERED BY WARRANTY.** Metal surfaces should be cleaned with a warm soapy solution and thoroughly rinsed. **NOTE: ALLOW CANOPY TO DRY COMPLETELY BEFORE ROLLING AWNING UP.**

CLEANING OMEGA II CASE

It is always a good practice to check the Omega II case to make sure it is free from debris. If debris such as twigs, pine cones, etc. were to collect in the case then the fabric could possibly be damaged when rolling the awning up and retracting the room. To check the case for debris or to remove any debris that may have collected in the case, do the following:

1. Make sure the slideout room is retracted completely.
2. Unlock Omega II arm locks.
3. With the pull cane, grasp center pull strap of the Omega II.
4. Pull downward on the Omega II pull strap until the case of the awning is as far down as possible and accessible to you. **Note: Once the case is low enough to be accessible, it will not automatically roll up by itself.**
5. With your hand, carefully remove any debris that may have collected in the case. If possible, take a water hose and run water throughout the case to remove any excess debris that you may not have been able to get by hand.
6. Once the case is completely cleaned out, grasp the pull cane and center pull strap with one hand and lift upward on the case with the other. Hang on to the pull strap. When the awning starts going up, once the case moves past 90degrees moving toward 45 degrees, then the spring tension will take over. Once the spring tension takes over, hang on to the pull strap and pull cane and carefully allow the Omega II to roll back up against the side of the coach.

SECTION VI:

WARRANTY

1. **Duration:** Two & Four Year Limited warranty. Two years parts labor and freight on canopy, four years parts labor and freight on springs, roller, and hardware.
 2. **Who gives this warranty?**
Carefree of Colorado, A Scott Fetzer Company (the "Company").
 3. **Who receives this warranty?**
The original purchaser (the "purchaser") other than for purposes of resale, of an Omega awning. This warranty is not transferable.
 4. **Responsibilities of the Company under this warranty?**
Repair or replace at Warrantor's option, of the covered part (parts) which Warrantor, in the exercise of its reasonable discretion, determines to be effective; provided that the Warrantor receives notice of the defect within the stated warranty period for the respective servicing dealer or agent for performing any repairs he respective product / component. Warrantor will also pay the authorized by Warrantor as per the terms of this warranty. Company will allow for freight and labor charges - labor is based on Flat Rate Form. CHARGES FOR TRAVEL TIME AND MILEAGE ARE NOT COVERED BY THE WARRANTY.
 5. **Responsibilities of the Purchaser under this warranty.**
 - A. Promptly notify seller, or alternately, the Company of any claim hereunder.
 - B. Retain dated proof of purchase for specified product and provide it as requested
 - C. Inspect the awning upon purchase to confirm the condition of the canopy and the proper operation of the product.
 - D. Perform "Periodic Preventative Maintenance" as specified in Owners Manual.
 - E. Deliver any product claimed or found defective during warranty period to the nearest Carefree of Colorado Authorized Service Dealer. The Original Purchaser is responsible for any expenses related to delivery or pick up of product to / from the Service Dealer. Visit carefreeofcolorado.com for the name of the nearest Authorized Service Dealer, or call Carefree at the number shown above.
 - F. At the option the Company return the product or part to Carefree of Colorado for inspection. Carefree Authorization to Return form must be obtained before any product or part is returned.
 - G. Use reasonable care in maintenance, operation, use and storage of the product in accordance with the instructions contained in the owner's manual.
 6. **What is covered by warranty?**
 - A. Defect's on the manufacturers material and workmanship of product under normal use, and which occur within the duration of the warranty period. On all awnings, the following parts are covered only as follows: (a) Fabrics, free from quality defects (normal wear and fading are excluded); (b) Roller Tube, against extrusion defects; (c) Springs (or motor) Assembly(ies), against breakage; and (d) Hardware, against extrusion defects.
 - B. Omega Awning Roller Tube – 4 Year Limited Warranty
Omega Awning springs are warranted not to break for four years. **THIS DOES NOT INCLUDE HIGH WINDS OR WATER POOLING ON THE CANOPY.**
 - C. Omega Awning Spring Assembly – 4 Year limited Warranty
Omega Awning Springs are warranted not to break or pull loose if not over-wound or subjected to high winds or water pooling on the canopy.
 - D. Omega Awning Canopy – 2 Year Limited Warranty
Omega Awning Canopy material is warranted against:
 - 1) Excessive fading (there is always slight color change due to ultraviolet rays):
 - 2) Mildew (however, mildew will form on dirt which has not been removed):
 - 3) Cracking, peeling, hardening, sagging or loss of strength if not subjected to high winds or water pooling on the canopy.
 7. **What is not covered under this warranty?**
 - A. Fabric damage such as pinholes or tears not reported within ten (10) calendar days of purchase.
 - B. Improper installation and / or any damage or failure that results from improper installation of the product, including fabric damage caused by improper installation.
 - C. Product abuse and normal wear. "Normal Wear" includes the occasional need to re-tension the awning.
 - D. Conditions that are not related to the materials or workmanship of the product:: including any failure the results from an accident, wind, rain, water pooling, or other acts of God; purchaser's abuse; neglect; failure to operate, or use or maintain the product in accordance with the instructions provided in the Owner's Manual supplied with the product; (failure to operate the product(s) in accordance with instructions in the Owner's Manual and on the product shall also include the removal or alteration of any product component or device. In the event of any such removal or alteration , this warranty is void).
 - E. Any component not sold or manufactured by the Company.
 - F. ANY INCIDENTAL, INDIRECT, OR CONSEQUENTIAL LOSS, DAMAGE, OR EXPENSE THAT MAY RESULT FROM ANY DEFECT, FAILURE , OR MALFUNCTION OF THE CAREFREE OF COLORADO PRODUCT. Some states do not allow the exclusion or limitation or exclusion may not apply to you.
 - G. Damage while traveling due to the awning not properly stowed.
 - H. Any failure that results from the use of another product with a Warrantor's product that is not specifically approved by the Warrantor.
 8. **When Warrantor will perform repair or replacement under warranty.**
 - A. Repair or replacement will be scheduled and performed according to normal work flow at the nearest Authorized Service Dealer, and depending on the availability of replacement parts.
 - B. If the Purchaser does not receive satisfactory results from the Authorized Service Dealer, the Purchaser should contact the Carefree of Colorado Customer Care Department.
- THIS WARRANTY GIVES YOU THE SPECIFIC LEGAL RIGHTS AND YOU MAY ALSO HAVE OTHER RIGHTS WHICH VARY FROM STATE TO STATE. No action to enforce this warranty shall be commenced later than 30 days expiration of the warranty period. The duration of this Limited Warranty also limits the duration of any implied warranty such as warranty of merchantability or fitness for a particular use or purpose . Some states do not allow such limitations so the implied warranty limitation may not apply to you. Carefree of Colorado reserves the right to change the specifications and design of any product without notice and with no obligation to make corresponding changes to products previously manufactured.

Carefree of Colorado

A Scott Fetzer Company
2145 W. 6th Ave.
Broomfield, Co. 80020
303-469-3324