



USA
SERVICE OFFICE
The Dometic Corp.
509 So. Poplar St.
LaGrange, IN 46761
219-463-4858

CANADA
Dometic Dist.
866 Langs Dr.
Cambridge, Ontario
CANADA N3H 2N7
519-653-4390

**For Service Center
Assistance Call:**
800-544-4881

Fabric Roller Tube Assembly with Square 1™ Hardware

WARNING

This Manual should be read and understood before installation, adjustment, service or maintenance is performed. This unit must be installed and serviced by a qualified serviceman. Modification of this appliance can be extremely hazardous and could result in personal injury or property damage.

INSTALLATION INSTRUCTIONS

MODEL Sunchaser

INSTALLATION

COVERED BY PATENT 4,524,791
OTHER PATENTS APPLIED FOR

REQUIRED PARTS (Packed with each Hardware Assembly)

- | | |
|------------------------------|---|
| (2) 1/4-20 Machine Screws | (1) Door Roller Kit, Containing: |
| (2) 1/4-20 Short Locknuts | (2) #10 Self-Drilling Screws |
| (8) #14 x 2 Screws | (1) Door Roller |
| (2) #10 Self-Drilling Screws | (1) Edge Guard |
| (2) Stop Washers | |
| (2) #6 Self-Drilling Screws | |

Application

The A&E Awning is designed and intended for use on motorhomes, mini-motorhomes, 5th wheels and travel trailers with straight sides.

IMPORTANT: Read and understand ALL of the following steps before beginning installation.

The Dometic Corporation reserves the right to modify appearances and specifications without notice.

Installation of A&E Awnings will at some points, require three people. Use the following procedure to assure a properly installed, and properly functioning awning.

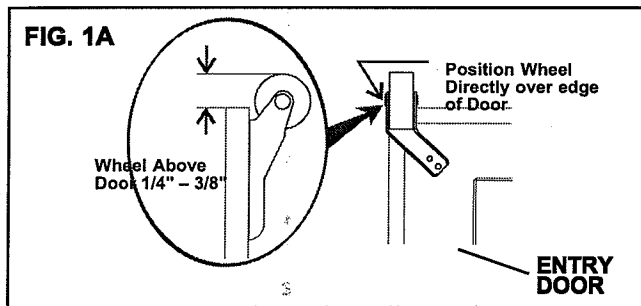

1. Where the A&E Awning is to be mounted above the entry door, the door roller must be installed on the exterior side of the door in the extreme upper corner above the door handle. (FIG. 1A)

In addition, if there is a screen door inside the regular door, a dooredge guard must be installed on the exterior side of the screen door, in the extreme upper corner opposite the door hinges. (FIG. 1B)

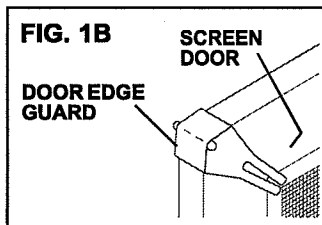

This allows the door roller or the edge-guard (instead of the sharp door corner) to contact the underside of the fabric when the entry or screen door is swung out while the awning fabric is extended low.

2. Carefully lay the fabric roller tube assembly on a clean, well padded "V" trough to prevent fabric damage. Working on the torsion lock end first, insert the arm cap into the arm, position the nail in the end cap to the front of the hardware, align and secure the arm assembly to

the torsion rod using the 1/4-20 machine screws, nylon washers, and 1/4" locknuts. (FIG. 2A) Align and attach the other end.

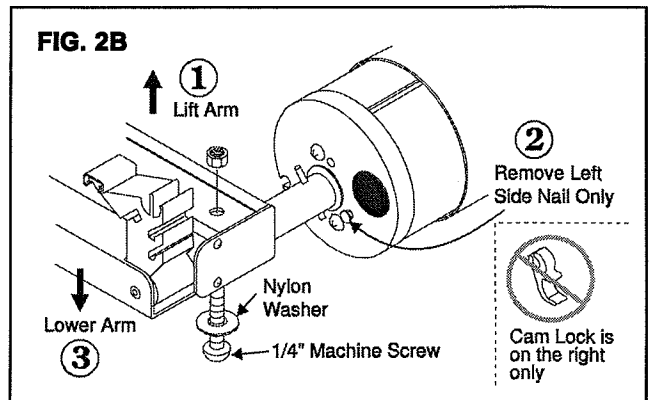
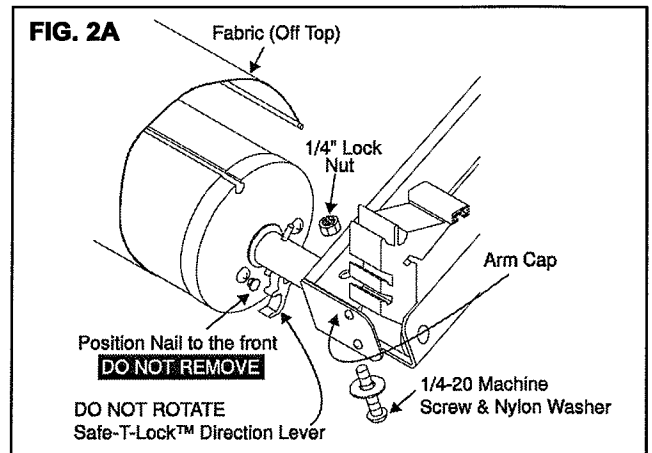

WARNING

DO NOT REMOVE the NAIL from the right end at this time and DO NOT attempt to rotate the Safe-T-Lock™ Lock Direction Lever until installation is complete. (Lever has been preset in the roll-down position.) (FIG. 2A)

3. Remove the left nail only. With both awning arms secured to the Fabric Roller Tube Assembly, and facing the floor, rotate the left arm clockwise as if rolling the fabric up. This takes the torsion pressure off of the nail. Remove the nail by hand and lower the arm to the floor. (FIG. 2B)
4. **DO NOT** remove the tape or spacer holding the arm and rafter together until the top brackets are installed. Prepare the awning rail to accept the awning roller cover by selecting the end from which the awning shall be fed, then widen that end of the rail with a flat screwdriver and remove burrs. (FIG. 3)
With one person grasping each support arm, carefully lift the entire assembly to an upright position.
Keeping the two arm assemblies **PARALLEL** to each other to avoid excessive twisting and possible damage to assembly, walk the awning to the prepared end of the awning rail (FIG. 4A)

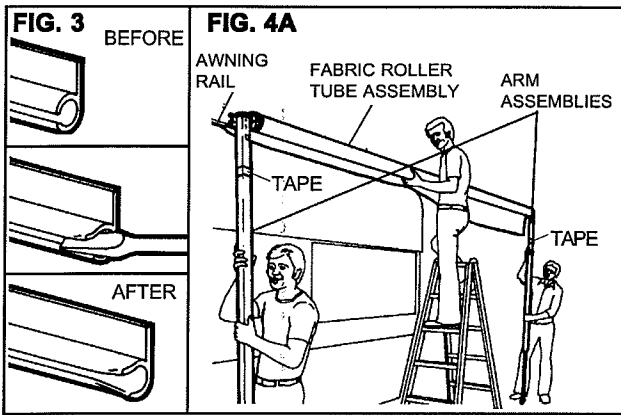

A third person is now required to guide the full awning into the awning rail while standing on a stepladder, while the other two walk the entire awning assembly to the desired position. (FIG. 4)

- Loosen the knobs and extend the arms to the ground. Position the pivot 2 inches above the awning rail. Retighten the knobs so the arms support the awning weight.

6. Install Top Mounting Brackets.

After the complete awning assembly has been slid into the awning rail, check to be sure that its position allows for solid mounting of the top and bottom brackets and that support arms are in desired location (not restricting use of doors, access doors, etc.). (FIG. 5A)

DO NOT untape or move the main support arm away from the top mounting bracket and rafter arm.

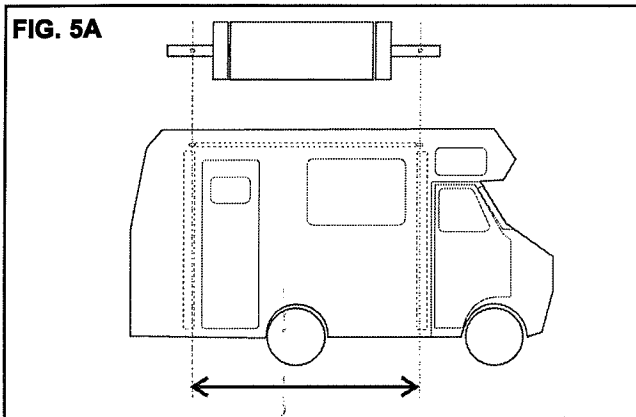

Swing the foot away from the coach as needed to lower the top pivot to the awning rail height. Insert the pivot into the awning rail as shown in FIG. 5B.

Position the top bracket in the top pivot. Alternate slots allow for use with various awning rails and constructions. (FIG. 5C, D, E)

Mark the top bracket hole locations. Pre-drill the two holes using a 3/16" drill bit. The hole should angle downward slightly. (Use 7/32" drill bit if drilling through steel). Install top bracket with two #14 hex. hd. screws (FIG. 5C, D, E). Use clear silicon to seal where the screw enters the coach. The main support arm cap will rest on the top pivot. Check that there is approximately 1/8 inch between the

arm and rafter on each side. Install remaining top mounting bracket using the same procedure. Remove the tape holding the awning arm and rafter together and unhook the travel straps after both brackets are installed.

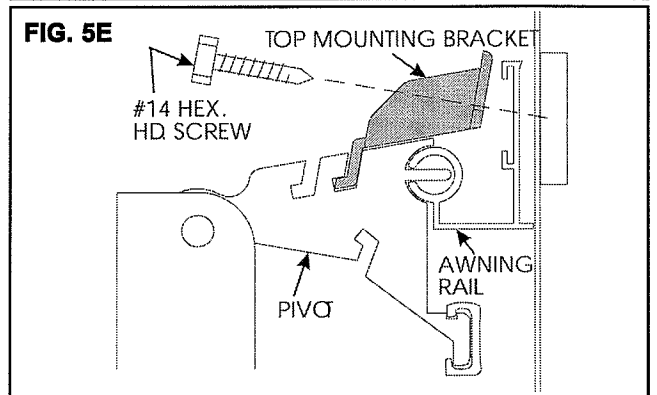
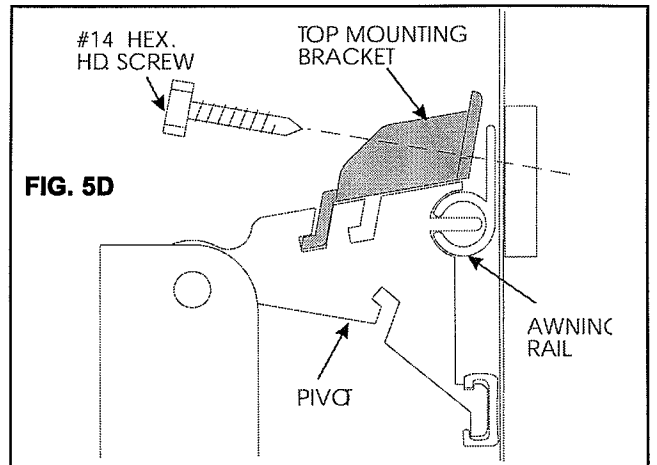
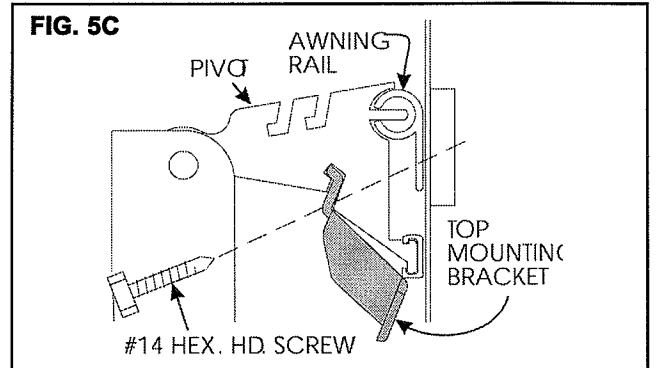
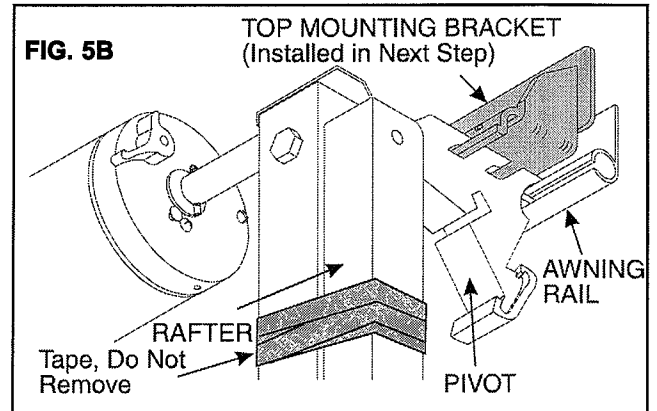

7. Installation of Bottom Mounting Brackets.

Position the bottom mounting bracket (FIG. 6) between 66" and 80" below the awning rail, centered on the main arm with the coach level. Always select the position that offers the best supporting structure for mounting the bottom bracket, i.e. mount directly into the floorline, molding, etc.

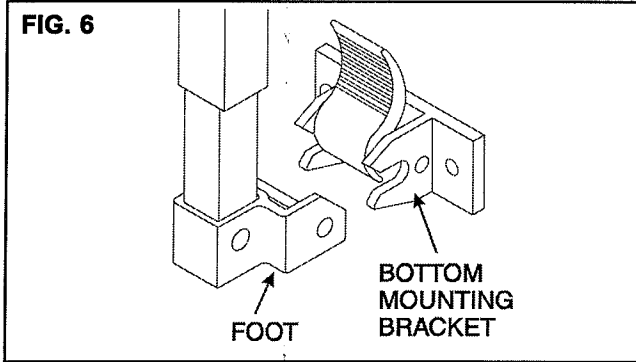

Mark position of bottom bracket so that both holes are positioned over the floorline. Predrill two 3/16" dia. holes through the marked locations. (Use 7/32" dia. if drilling through steel).

Secure bracket using two #14 hex head screws. (FIG. 6B). Use clear silicon to seal where the screw enters the coach. Repeat for other side.

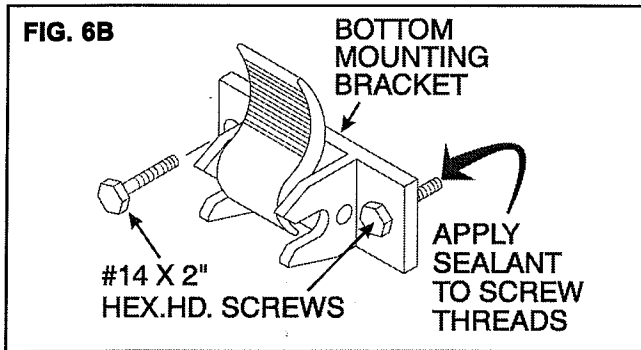

! CAUTION

The bracket must be mounted level. When installing over a molding, A&E Stand-Off Kit, Part No. 3104781, may be used.

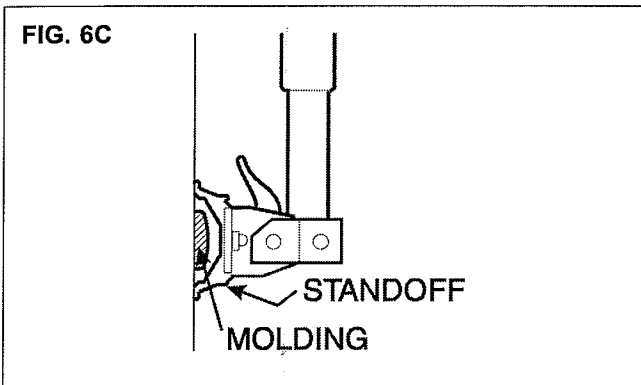

8. Installation of Stop Washer

CAUTION:

- 1) This step is essential for the proper functioning of all A&E Awnings.
- 2) The top brackets (FIG. 5) must be bolted tight to the coach to ensure proper stop washer location and proper awning function.

A. Ensure the arm cap is above the rafter pivot. Hold the arm snug to the rafter. Loosen the arm knob slowly so the arm lowers onto the rafter pivot. Raise the inner arm to where the foot is at the bottom of the foot bracket and retighten the knob. (FIG. 7A)

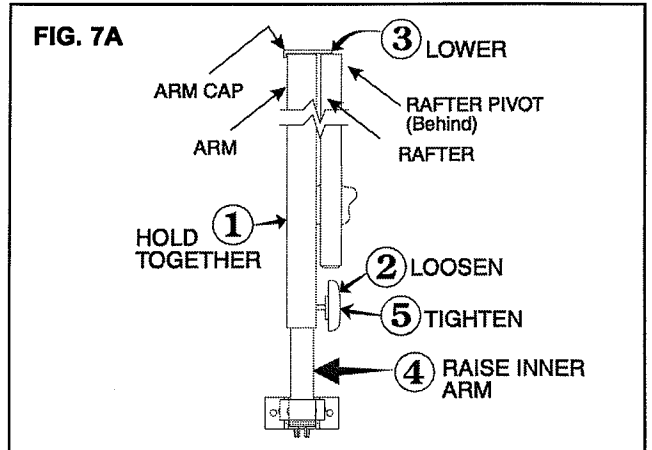

B. Lift the weight of the awning with the arm and snap the foot into place. (FIG. 7B)

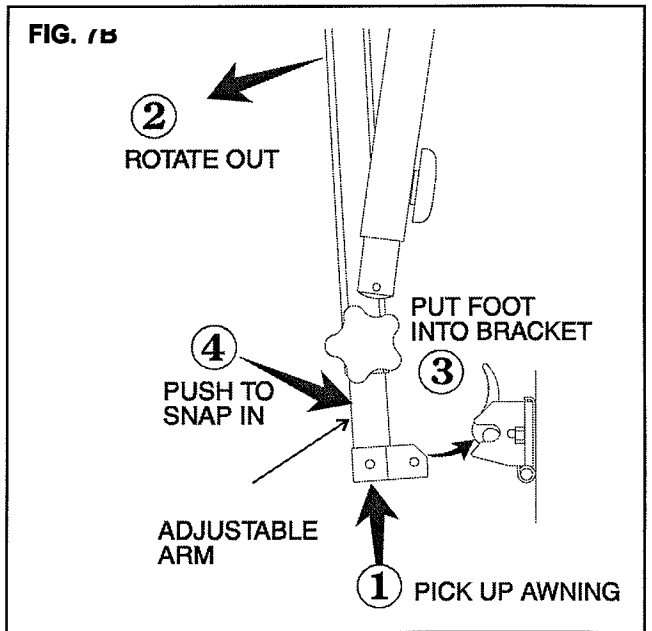

C. (Refer to FIG. 7C)

- 1) Rotate the arm to the coach, holding it against the rafter again.
- 2) Loosen the rafter knob so the rafter will slide within the arm.

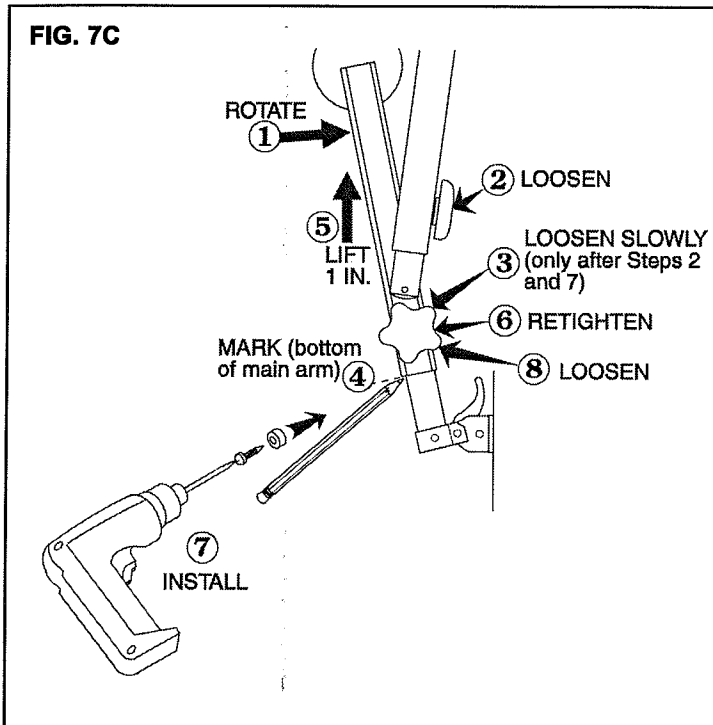
FIG. 7C

- 3) Loosen the arm knob slowly, letting the arm cap settle onto the rafter pivot.
- 4) Mark the stop bolt location lightly at the very bottom of the main arm in the center of the adjustable arm.
- 5) Lift the arm 1 inch and
- 6) Retighten the arm knob.
- 7) Install the stop plug with (1) #10 self-drilling screw centered to 1/8" above the marked line.
- 8) Loosen the arm knob, letting the weight settle onto the stop plug.

The main support arm cap should completely clear the main rafter and pivot as it swings toward the vehicle. Repeat for other side. (You may need to push the other arm, rotating the awning to the coach wall).

9. Releasing Pre-Set Tension.

! WARNING

When removing nails, keep hands clear of hardware and roller tube. Springs are under tension and the awning will attempt to close.

The nail is found in the roller tube end cap (FIG. 8). Twist the roller tube as if unrolling awning while pulling the nail by hand and discard.

Remove wire tie from the Safe-T-Lock™ Lever. Rotate the lever to the roll up position and allow the awning to roll up. The awning should now roll up snugly against the vehicle side. If no tension is felt, check to make sure the Safe-T-Lock™ Lever is in the roll-up position.

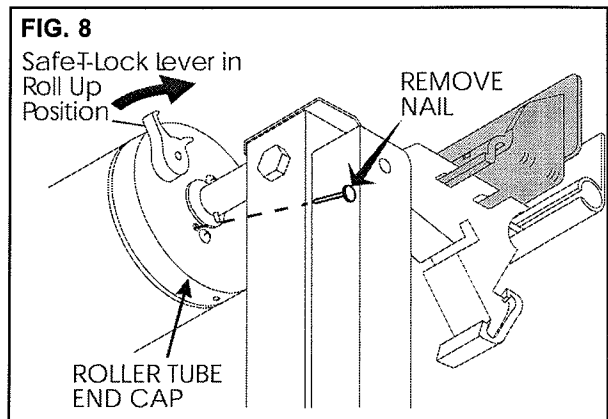
FIG. 8

10. Securing Awning

The fabric must be secured from shifting within the awning rail.

Open and close awning a few times to allow for natural self adjustment of awning. Track the strap slightly to one side as it closes to avoid bulging over the extra thickness of material and stretching the fabric.

With the awning closed, the fabric will locate itself between the two top brackets. Pull the main arm sideways to the rafter so there is no gap between them. The fabric will move with the roller tube. Measure in 2" from the edge of the fabric and secure by driving a #6 self-drilling screw through the rail and into the fabric rope. (FIG. 9)

Repeat at other end, hold the main arm against the rafter while securing the fabric.

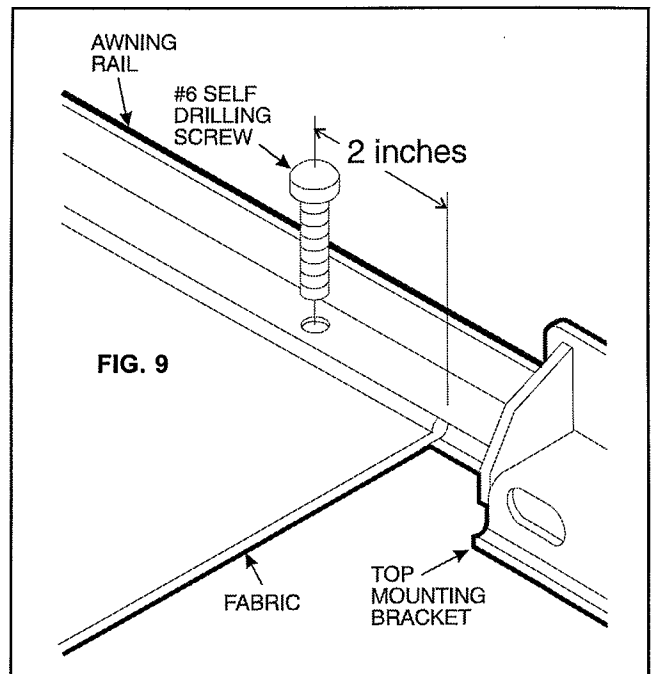
**FIG. 9**

11. Operate awning according to the Operating Instructions to check that all parts function properly.

12. Re-secure the travel straps.