



# Bed Hardware Owners Manual

## Part #901402000 and #901403000

### Overview

The bed hardware is designed to support a bed system and provide maximum utilization of the area within the RV.

The maximum weight rating for persons and gear is 450 lbs. for the queen bed hardware (#901402000) and 300 lbs. for the twin bed hardware (#901403000.)



**SAFETY NOTE:** The bunk system has a safety pin included on both side mounted mechanisms to prevent the bunk hardware from falling from the retracted or up position. This pin should be in place at all times when the unit is in the up position to prevent possible user injury. See *Figure 1*.

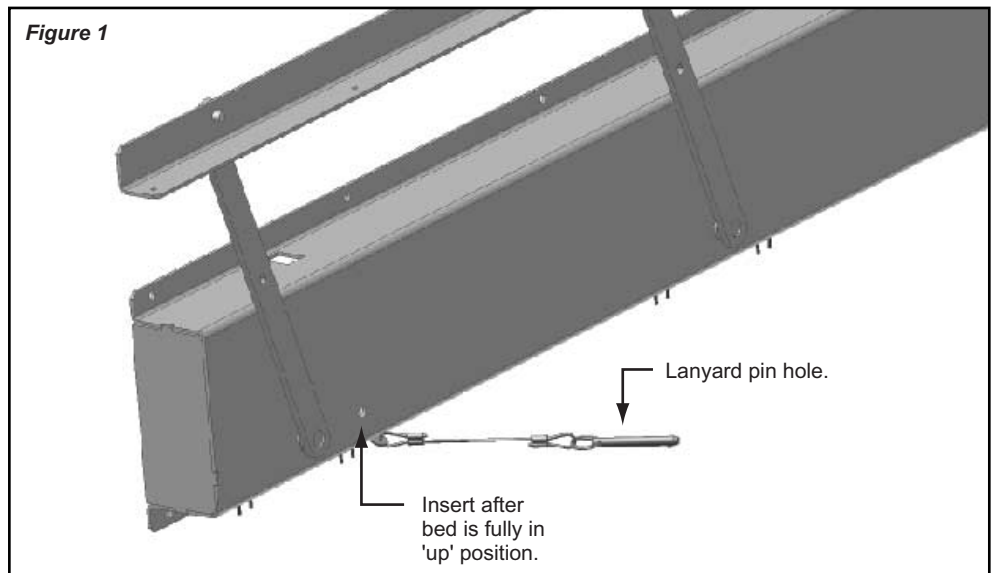

### To Lower Bed

To lower the bed, remove lanyard pins from both the right and left side.

Stand mid-way between the two sides of the bed. Pull toward yourself and down on the bed frame. Fully cycle the bed by pulling it all the way down to the lowest position. You will feel the bed mechanism stop and make contact internally with the rubber bumpers.

### To Raise Bed

To raise the bed, stand mid-way between the two sides of the bed. Pull up on the bed frame, raising it all the way to the 'up' position. Insert the lanyard pins on both the left and right side. If you have problems inserting the lanyard pins check that the bed is in the fully 'up' position.

When the mechanism is in the 'down' position it will stay down until the mechanism is manually lifted to the 'up' position.



**Kwikkee Products Company, Inc.**  
230 Davidson Avenue  
Cottage Grove, Oregon 97424-9545  
(541) 942-3888  
[www.kwikkee.com](http://www.kwikkee.com)

### Assembly of the Bed Mechanism

If required, the spring mechanism may be assembled inside the channel assembly. Assemble referring to **Figure 2**.

Slip one end of the spring over the moveable spring anchor. Slip the other end of the spring over the spring tensioner. Be sure that spring ends are fully engaged in cut-outs.

Insert the tensioning bolt through the hole in the vertical channel. Place the gold-colored washer behind the head of the bolt.

Thread the bolt into the end of the spring tensioner. Tighten the tensioner bolt until there is approximately 3/4" between it and the edge of the channel.

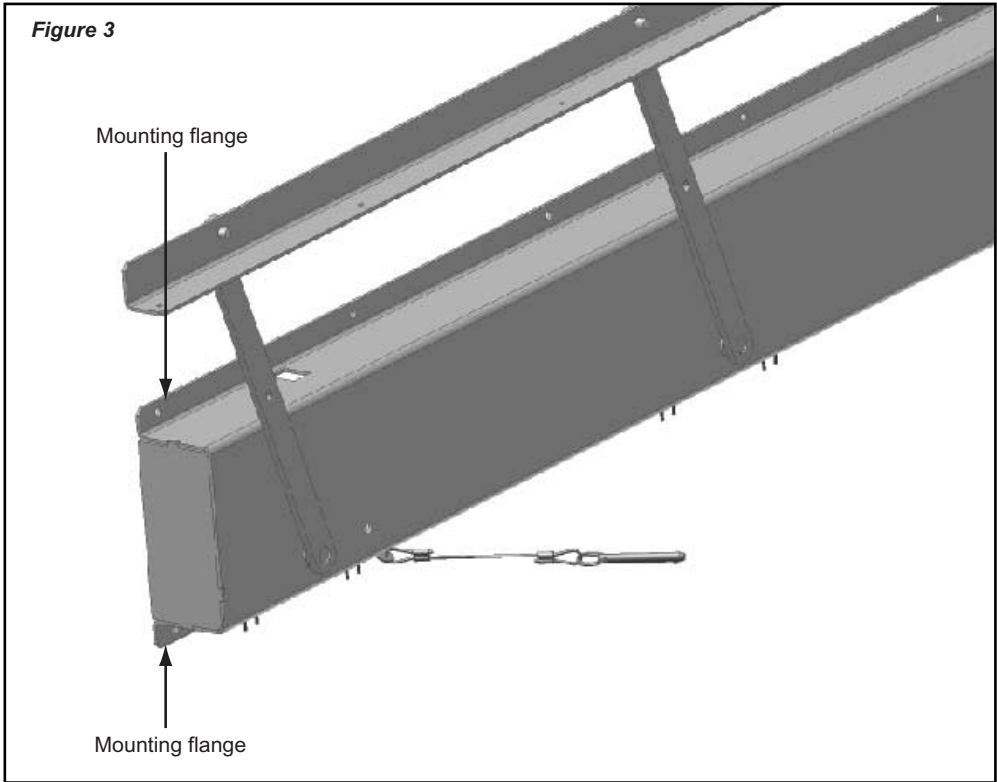
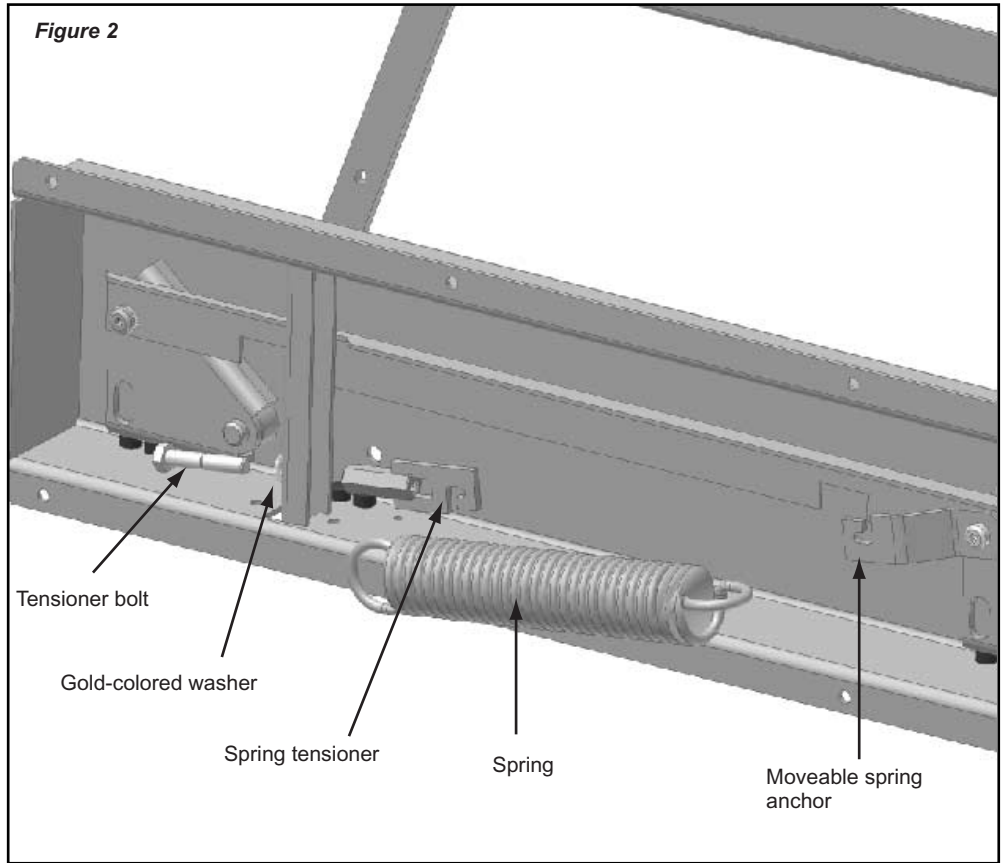

### Mounting the Assembly

Mount the assembled bed hardware along the mounting flange (see **Figure 3**) to a suitable surface on an exterior wall. Be sure that the surface is sufficiently strong to support the weight of the bed hardware, bed frame, occupants, and gear.

Check all applicable codes prior to mounting.