

PYRAMID
U.S.A.

Gold
Series

CDR42DX

INSTRUCTION MANUAL

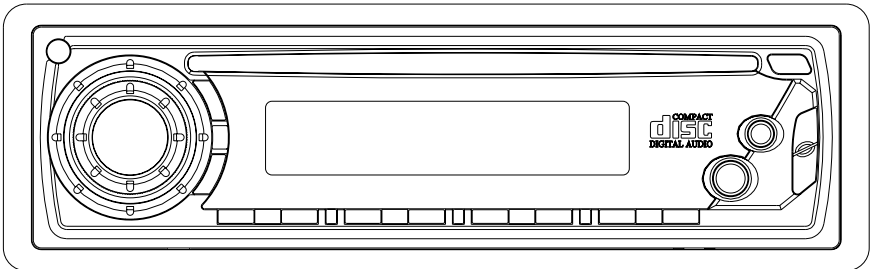

**ANTI-THEFT FULL DETACHABLE SYSTEM
AUTO-LOADING COMPACT DISC PLAYER
AM/FM-MPX WITH MANUAL TUNING RADIO**

BASIC OPERATION

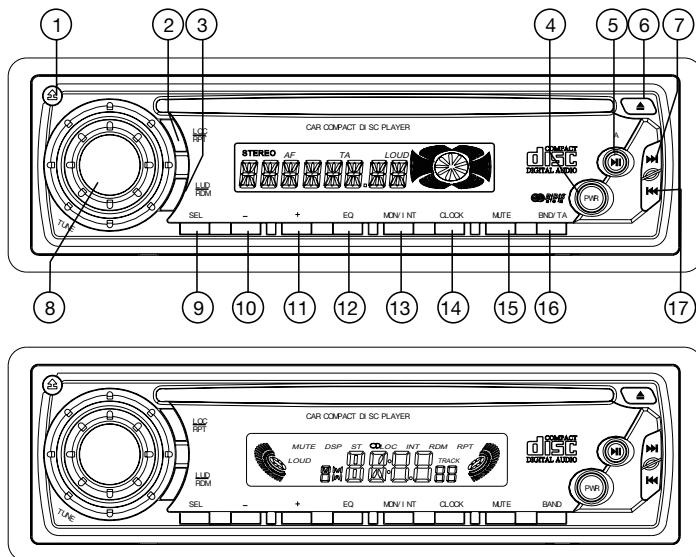

1. RELEASE BUTTON

Press it to detach the front panel when you want to take the unit away.

2. LOC/RPT BUTTON

LOCAL/DISTANCE MODE:

When in the radio mode, press it to select local or distance broadcast station receive sensitivity. The word LOC will appear on LCD during local state.

Attention: During AM mode, LOC is non-functional.

REPEAT MODE:

During CD mode. Press RPT button to repeat a single track.

3. LUD/RDM BUTTON

LUD MODE:

When reduce the volume to half level, press it to enhance the bass effect.

RDM MODE:

During CD mode, press it and hold for 5 seconds, it display " RDM " and Random function performs.

4. POWER BUTTON

Press it to turn on or off the unit.

5. CDP/AF (FOR RDS) BUTTON

When in RADIO mode, press the button to change into CD playing, press it again to pause the CD playing, press it again to return back to CD playing. AF [ALTERNATIVE FREQUENCIES] (FOR RDS ONLY)

BASIC OPERATION

1. By pushing short.

1) RADIO mode

changed the mode to CDP mode.

2). CDP mode

changed the PLAY mode to PAUSE mode and vice versa .

2. By pushing long.

It is engaging whether "AF SEARCH" mode ON or OFF .

If " AF SEARCH" mode is turned on, the 1'st AF is displayed on the LCD. All the AF list can be shown by pressing "DISPLAY" key during "AF SEARCH ON" mode.

When AF is shown, the display mode changes to the frequency if the user changes the frequency.

RDS signal is NOT received during AF search mode.

This mode is released after few seconds. But, this mode is NOT released during changing the tuned frequency to search AF.

6. EJECT BUTTON

Press it to eject the CD DISC.

7.17. TRACK UP/DOWN BUTTONS

During CD mode, press ►► button allow you to track forwards.

Hold the ◀◀ button allow you to skip forwards.

8. TUNING BUTTON

Rotate TUNING knob clockwise or anticlockwise to adjust the frequency upward or downward.

9.10.11. SEL (AUDIO MODE SELECT) / +/- BUTTONS

Press SEL button to change the mode in the sequence of

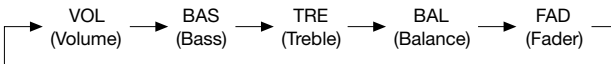

A. The volume level can be adjusted at any time by pressing the audio level+ or - button as select mode has been initially defaulted at volume mode.

B. The volume level is also obtained by stepping through the SEL button until the function VOL is displayed and then press + or - button to adjust the sound level.

C. Press and hold the + or - button to adjust the sound level.

D. Adjust sound balance between front and rear speakers by using + and - buttons.

12. EQ BUTTON

Press it to switch between 3 preset equalizer curves: POP, CLAS, ROCK. The sound quality will be changed.

13. MO/INT BUTTON

MO MODE: Press it to select mono or stereo mode.

INT MODE: During CD mode, press " INTRO " button to hear the first 10 seconds of each track on the disc. Press this button again to restore the player to its normal play mode.

14. CLOCK ADJUSTMENT BUTTON

1. "NO AF SEARCH" mode.

When pressed short, it is operated as the conversion of each display mode as follows.

- In FM mode : (PS) -> (CLOCK)-> FREQ. -> (PTY) ->

BASIC OPERATION

- In CDP mode : CDP -> (CLOCK)-> (PS)-> FREQ. -> (PTY) ->
Each displaying time is 5 sec, and comeback to 1'st position after 5 sec.
When pressed long, until time flashes. and you can adjust time now.

To adjust hour:

with time be flashed on display, push the tune **◀** button to adjust hour,
when adjustment is completed, release the button.

To adjust minute:

with time be flashed on display, push the tune **▶** button to adjust minute.
When adjustment is completed, release the button.

2. "AF SEARCH" mode.

When "AF SEARCH" mode is selected ("AF" segment is turned on), pressed short,
it shows each "AF" sequentially.

15. MUTE BUTTON

Press it to eliminate the sound immediately.

16. BAND/TA (FOR RDS) BUTTON

Press it to select your desired radio band and the band which is selected will be displayed on LCD.

TA function [TRAFFIC ANNOUNCEMENT] BUTTON (FOR RDS ONLY)

When pressed short ,

1). RADIO mode

Depending on the installed option diode matrix, LW/MW/FM band is toggled cyclically through the tuning bands.

-> FM -> MW -> LW (for 3 bands Europe) or
-> FM -> MW -> (for 2 bands Europe) or
-> FM -> AM -> (for 2 bands USA) or

Refer to the explanation of diode matrix.

2). CDP mode

changed the mode to Radio mode.

When pressed long, it is engaging whether TA mode on or off.

When TA mode is on and a traffic announcement is transmitted:

TA (INFO) - When the unit was in CDP mode, it will switch temporarily to radio mode.

- If the volume level was under the threshold point it will be raised to the threshold point.

But the user changed the volume level which was more than the threshold point.

(min .TA volume level), it will be set to the last level.

When TA mode is on,TA of individual segment is turned on.

- When a TP station is received, TP of individual segment is turned on.

The current traffic announcement is canceled by pressing this key. But the TA mode will not be off.

ELECTRIC CONNECTION

FOR 4X7W or 4X25W

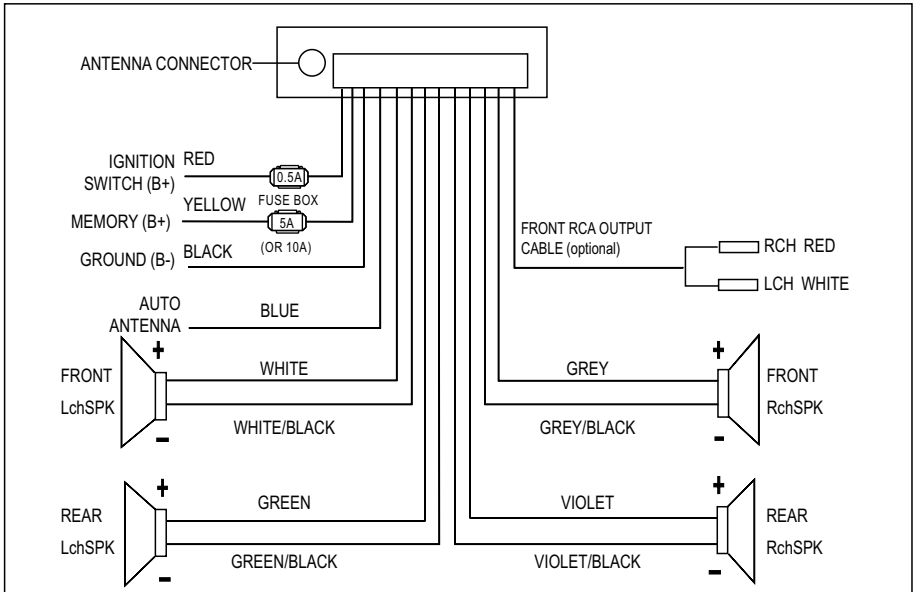

FOR 2X7W

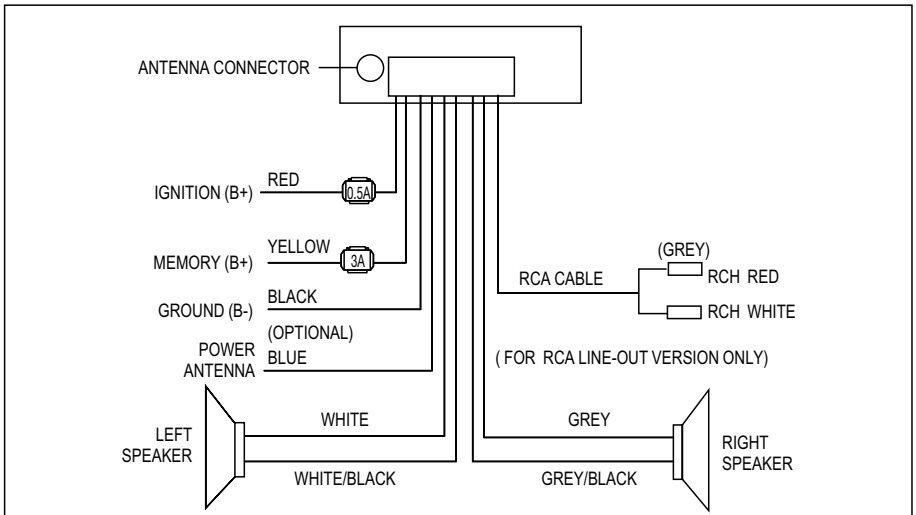

NOTE:

In spite of having any kinds of speaker system, must use 4 ohms impedance of speaker to reduce the distortion during high volume level.

INSTALLATION

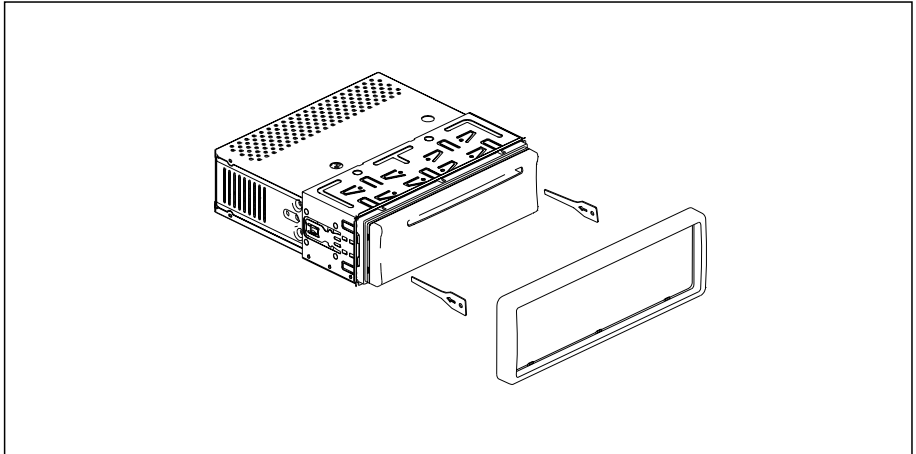
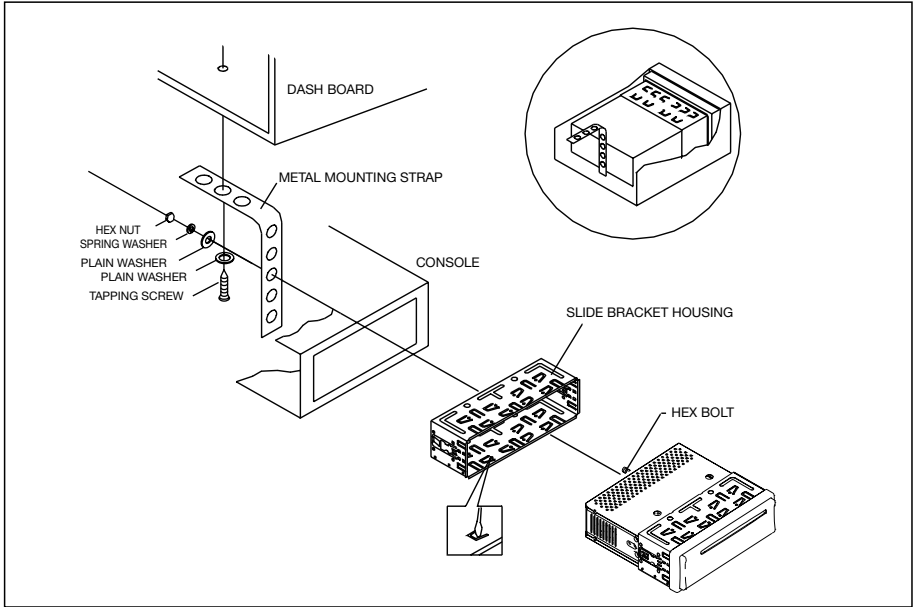

DISC NOTES

DISC PLAY:

Cleaning discs

Before playing, clean the disc with a clean, lint-free.

Flip the disc in the direction of the arrow.

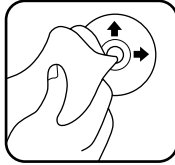

NOTE:

Do not use so solvents such as benzine, thinners. Commercially available cleaners or anti static spray damage the unit.

Insert a disc with the label surface down. Doing so may damage the unit.

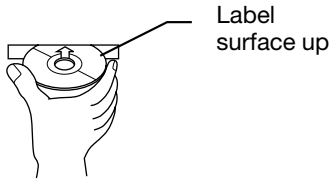

NOTE:

Do not try to insert another disc when one has been already inserted.

Doing so may damage the unit.

Handle the disc by its edge. And to keep the disc clean, do not touch the surface.

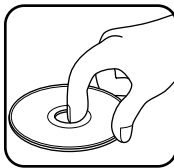

Do not stick paper or tape on the disc.

Do not expose the disc to direct sunlight or heat sources such as hot air ducts. Or leave it in a car parked in direct sunlight where there can be a considerable rise in temperature.

SPECIFICATIONS

Supply voltage : 12V DC (11V-15V), test voltage 14.4V, negative ground

Current consumption : Less than 5A

Audio signal output

Characteristics : (1) Frequency response 20 Hz-20 kHz
 (2) S/N ratio 80 dB (JIS)
 (3) Wow and Flutter Below measurable limits

	For 3 Bands (Europe) FM	For 2 Bands (Europe) FM	For 2 Bands (U.S.A.) FM
Frequency Coverage	: 87.5 to 108 MHz	: 87.5 to 108 MHz	: 87.5 to 107.9 MHz
IF	: 10.7 MHz	: 10.7 MHz	: 10.7 MHz
Sensitivity (S/N = 30 dB)	: 20 dBu	: 20 dBu	: 20 dBu
Stereo Separation	: > 30 dB	: > 30 dB	: > 30 dB

	MW	MW	AM
Frequency Coverage	: 522 to 1620 KHz	: 522 to 1620 KHz	: 530 to 1710 KHz
IF	: 455 KHz	: 455 KHz	: 455 KHz
Sensitivity (S/N = 20 dB)	: 40 dBu	: 40 dBu	: 40 dBu

LW (optional)

Frequency Coverage : 145 to 280 KHz
 IF : 455 KHz
 Sensitivity (S/N = 20 dB) : 45 dBu

Note:

Specifications and design are subject to modification, without notice, due to improvements in technology.

TROUBLE SHOOTING

Before going through the check list, check wiring connection. Should any of the problems persist after check list has been made, consult your nearest service dealer.

Symptom	Cause	Solution
No power.	The car ignition switch is not on.	If the power supply is properly connected to the car accessory terminal, switch the ignition key to "ACC".
	The fuse is blown.	Replace the fuse.
Disc cannot be loaded or ejected.	Presence of disc inside the player.	Remove the disc in the player, then put a new one.
	Inserting the disc in reverse direction.	Insert the compact disc with the label facing upward.
	The disc is extremely dirty or defective.	Clean the disc or try to play a new one.
	Temperature inside the car is too high.	Cool off or until the ambient temperature return to normal.
	Condensation.	Leave the player off for an hour, then try again.
No sound.	Volume is in minimum.	Adjust volume to a desired level.
	Wiring is not properly connected.	Check wiring connection.
Sound skips.	The installation angle is more than 30 degrees.	Adjust the installation angle less than 30 degrees.
	The disc is extremely dirty or defective disc.	Clean the compact disc, then try to play a new one.
The operation keys do not work.	The built-in microcomputer is not operating properly due to noise.	Press the RESET button. Front panel is not properly fixed into its place.
The radio does not work.	The antenna cable is not connected.	Insert the antenna cable firmly.
	The signals are too weak.	Select a station manually.

