

INSTALLATION, OPERATION AND SERVICE MANUAL



RECREATIONAL VEHICLE
DROP-IN COOKTOPS



Models
SD2 • SD3

FOR YOUR SAFETY

WARNING: IF THE INFORMATION IN THIS MANUAL IS NOT FOLLOWED EXACTLY, A FIRE OR EXPLOSION MAY RESULT CAUSING PROPERTY DAMAGE, PERSONAL INJURY OR DEATH.

DO NOT STORE OR USE GASOLINE OR OTHER FLAMMABLE VAPORS AND LIQUIDS IN THE VICINITY OF THIS OR ANY OTHER APPLIANCE.

WHAT TO DO IF YOU SMELL GAS

- DO NOT TRY TO LIGHT ANY APPLIANCE. EXTINGUISH ANY OPEN FLAME INCLUDING CIGARETTES.
- EVACUATE ALL PERSONS FROM THE VEHICLE.
- DO NOT START THE VEHICLE'S ENGINE OR ELECTRIC GENERATOR.
- DO NOT TOUCH ANY ELECTRICAL SWITCH (INCLUDING LIGHTS) OR USE ANY PHONE OR RADIO IN THE VEHICLE.
- SHUT OFF THE GAS SUPPLY AT THE GAS CONTAINER (BOTTLE) OR SOURCE.
- IMMEDIATELY CALL YOUR GAS SUPPLIER FROM A NEIGHBOR'S PHONE.
- FOLLOW THE GAS SUPPLIER'S INSTRUCTIONS.
- IF YOU CANNOT REACH YOUR GAS SUPPLIER, CALL THE FIRE DEPARTMENT.
- DO NOT TURN ON THE GAS SUPPLY UNTIL THE GAS LEAK(S) HAVE BEEN REPAIRED.

INSTALLATION AND SERVICE MUST BE PERFORMED BY A QUALIFIED INSTALLER, SERVICE AGENCY OR THE GAS SUPPLIER.

IMPORTANT:

INSTALLER: PROVIDE THIS MANUAL TO THE OWNER/USER OF THE RECREATIONAL VEHICLE.
OWNER: RETAIN THESE INSTRUCTIONS AND WARRANTY FOR FUTURE REFERENCE.
READ THIS MANUAL CAREFULLY BEFORE OPERATING APPLIANCE.
FOLLOW ALL SAFETY NOTICES AND WARNINGS.

ALL TECHNICAL AND WARRANTY QUESTIONS SHOULD BE DIRECTED TO THE COMPANY LISTED ON THE WARRANTY, OR RATING PLATE LOCATED UNDERNEATH THE MAIN TOP.



Suburban
Manufacturing Company

a subsidiary of AIRXCEL, Inc.

SUBURBAN MANUFACTURING COMPANY

Post Office Box 399
Dayton, Tennessee 37321
423-775-2131
FAX: 423-775-7015

SAFETY INFORMATION

- Listed below are some very important facts that you should follow. They are listed for your protection and safety.
1. Have your dealer show you where the main gas shut-off valve is located and how to shut it off in an emergency.
 2. Use your cooktop only for its intended use. It is not to be used as a means to heat your RV. Using your cooktop in this manner can result in personal injury/property damage and/or loss of life.
 3. If the cooktop is near a window, proper precautions should be taken to prevent curtains from blowing over burners creating a fire hazard.
 4. Keep the area around the cooktop clean and clear of any combustible materials, gasoline or other flammable vapors and liquids.
 5. Do not leave children alone or unsupervised in area where cooktop is being used. The top burners, burner grates and other areas near the burners become hot enough to cause severe burns.
 6. Children should be taught that the cooktop is not a toy. They should not be allowed to play with the controls or any other parts of the appliance.
 7. Do not store items of interest to children in cabinets above or near the cooktop. Children climbing on the appliance to reach items could be seriously injured.
 8. Do not wear loose fitting clothing or long-hanging sleeved clothing while using the appliance. If they contact the open flame of the burner, they could ignite and cause severe burns.
 9. Use only dry potholders to remove hot utensils. Using damp potholders on hot surfaces could result in burns to hands. Do not use a towel or bulky cloth for a pot holder. The cloth could contact open flame and catch fire.
 10. Never heat an unopened container. Pressure build-up within the container can cause it to explode.
 11. Keep cooktop clean. The build-up of grease and food boil-over and/or spillage can create a fire hazard.
 12. Avoid using your cooktop or any other appliance if you smell gas. Do not assume that the smell of gas in your RV is normal. Any time you detect the odor of gas, it is to be considered life threatening and corrected immediately. Extinguish any open flames including cigarettes and evacuate all persons from the vehicle. Shut off gas supply at LP gas bottle. (See safety notice on front cover of this manual.)

OPERATING INSTRUCTIONS

1. Know which knob controls which burner. Always be sure the correct burner is turned on.
2. Depress knob and turn fully counter-clockwise ↶ to "Lie" position.
 - a. Verify sufficient gas supply before attempting to light the burner. Air in the gas line will significantly delay burner ignition. The burner may light unexpectedly as the air in the line clears and is replaced by LP gas. This unexpected ignition could burn you. Air in the gas lines may occur after the vehicle gas bottle and/or tank is refilled, during and after servicing other appliances on same gas line, etc.
 - b. Do not attempt to light more than one burner at a time.
 - c. Immediately light burner by holding a long match near the burner ports. **CAUTION: Hand held lighters may be used but be sure they are the type designed for lighting open flame burners.**
3. If any burner should extinguish after initial lighting or due to accidental blow-out, turn gas off by turning control knob clockwise ↷ to "OFF", wait five (5) minutes, before attempting to relight the burner. Failure to follow these instructions could result in a fire or explosion.

If the burner should go out while cooking, or if there is an odor of gas, turn control knob(s) clockwise ↷ to "OFF". Wait five (5) minutes for gas odor to disappear. If gas odor is still present - Do not relight burners. See "What To Do If You Smell Gas" on the front cover of this manual.
4. To turn burner(s) "OFF", turn the appropriate control knob clockwise ↷ to "OFF".

WARNING! Be sure all control knobs are turned "OFF" when you are not cooking. Someone could be burned or a fire could start if a burner is accidentally left on or unattended even if only momentarily.

MAINTENANCE

WARNING! If the user of this appliance fails to maintain it in the condition in which it was shipped from the factory or if the appliance is not used solely for its intended purpose or if appliance is not maintained in accordance with the instructions in this manual, then the risk of a fire and/or the production of carbon monoxide exists which can cause personal injury, property damage or loss of life.

13. Turn pan handles inward or toward back of cooktop and out of the way of people walking past cooktop and/or out of the reach of children. Do not turn handles to where they are over the burners.
14. Do not use water on grease fires. Never pick-up a flaming pan. Smother a flaming pan with a lid or flat pan. Flaming grease outside the pan can be extinguished with baking soda or a multipurpose dry chemical fire extinguisher.
15. Never leave top burner(s) unattended.
 - a. For such reasons as down drafts that could be created by opening and closing of cabinet doors or doors within the RV or by positive or negative air pressures affecting burners due to improper installation. (See paragraph 6 under Installation.) The burner could extinguish resulting in gas escaping into the RV. Remember gas to burners is controlled manually, you must turn gas "ON" and "OFF".
 - b. A boil over could occur and the spill could ignite.
16. Flame size
 - a. Never extend the flame beyond the outer edge of the utensil. A higher flame simply wastes heat and energy.
 - b. Correct flame size is determined by utensil size and material, what you are cooking and whether or not you are cooking with liquid.

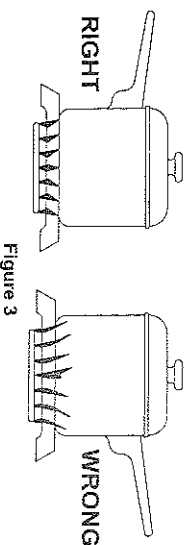

Figure 3

17. To prevent damage to the cook top, top burners, or top grate, never operate a top burner without a pan in place. The top burners, especially the high input burner (if equipped), should not be operated on high for an extended period of time.
- Use the high flame setting to begin, then reduce the flame to a lower setting to continue cooking. Never use cookware which extends beyond one inch of the grate, or rests over two operating top burners. This will cause excessive heat build-up which results in damage to the grate, top burner, and cook top.

1. Make sure all controls are "OFF" and the drop-in cooktop is cool before cleaning.
 2. Make sure that all cooktop surfaces, burner grates and burners are cool before cleaning or disassembling cooktop.
 3. Do not use oven cleaners, bleach or rust removers on the cooktop or burner grates.
 4. Do not obstruct the flow of combustion and ventilation air.
 5. Clean all surfaces as soon as possible after boil overs or spillovers.
 6. Use warm soapy water only to clean the burner grates, cooktops, painted surfaces, porcelain surfaces, stainless steel surfaces and plastic items on your drop-in cooktop. Do not use grit or acid-type cleaners.
 7. Do not use steel wool or abrasive cleaners. They will damage your drop-in cooktop. Use only non-abrasive plastic scrubbing pads.
 8. Do not allow foods containing acids (such as lemon or tomato juice, or vinegar) to remain on porcelain or painted surfaces. Acids may remove the glossy finish.
 9. Do not wash warm porcelain surfaces. Allow these areas to cool before cleaning. You could burn yourself or the porcelain could crack.
 10. Pitting and discoloration will result if spills are allowed to remain for any length of time on stainless steel.
 11. Do not allow spillovers to remain on the burner caps. The caps could be permanently stained if spillovers are not cleaned up promptly.
 12. If any of the burner ports or the orifice are clogged, carefully clean with a small wire or needle. Be sure not to enlarge ports. Never use a wire brush for cleaning burner ports or orifice. Never use any brush which may "shed" bristles, which may become lodged in the orifice or burner ports and cause a fire or explosion.
- ### TO REMOVE THE STOVE TOP
1. Remove the two (2) thumb screws from the sides of the stove top. Lift the stove top clear of the burner box.
 2. To reinstall top, reverse the procedure.
- ### TO REMOVE GRATE(S)
1. Remove the top.
 2. From the underside of the top, remove the clips from the grates by squeezing the ends of the clips together to release the tension of the grate.
 3. To reinstall grate(s) reverse the procedure.

INTRODUCTION

1. Your Drop-in Cooktop has been certified by Underwriters Laboratories (UL) for the U.S.A. and Canada for use with LP/Propane gas only.
2. Your cooktop is one of the following models: SD2 or SD3.
3. Model number letter designation:
 - S - Suburban
 - D - Drop-in
 - # - Number of burners
4. The complete model, serial number and stock number are located on the UL label located under the top. This information will be needed when servicing appliance or ordering parts. Record the information below and retain for future reference. Replacement parts can be ordered through your local dealer or Suburban Service Center. To obtain information on locating a local service agency, call Suburban Manufacturing Company, Customer Service Department, (423) 775-2131.

Model No. _____ Stock No. _____
 Serial No. _____ Date of Purchase _____

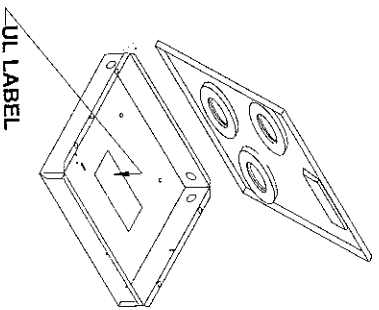

Figure 1

5. The cooktop is designed certified for use with LP/Propane gas only. Do not attempt to convert to natural gas.
6. Gas supply pressure for checking of the regulator setting shall be at least 4" W.C. above the suggested manifold pressure.
 Minimum Gas Supply Pressure - 11" W.C.
 Maximum Gas Supply Pressure - 14" W.C.

INSTALLATION

WARNING! Installation of this appliance must be made in accordance with the written instructions provided in this manual. No agent, representative or employee of Suburban or other person has the authority to change, modify or waive any provision of the instructions contained in this manual.

1. In the U.S.A., the installation must conform with state or other codes or in the absence of such codes, refer to the latest edition of:
 - a. Standard for Recreational Vehicles: ANSI A119.2/AFPA 501C
 - b. National Fuel Gas Code ANSI Z223.1
- In Canada, the installation must be in accordance with:
- a. Standard CAN/CSA Z-240.4.2-M86, Installation, Requirements for Propane Appliances and Equipment in Recreational Vehicles.
 - b. Any applicable local codes and regulations

Models	2. Minimum clearances from combustible walls above and below counter.				
	Below Counter	Center of Burner Head(s) to adjacent vertical combustible material above the cooking surface burners.	Right Sidewall	Left Sidewall	Backwall
SD2	0"	5 7/8"	5 7/8"	8"	8"
SD3	0"	5 5/8"	6"	8"	8"

3. Cut-out dimensions illustrated in Figure 2 are as follows:

Model	Dimensions				
	A	B	C	D	E
SD2	16 3/8	11 5/8	2 3/16	3/4" min.	18"
SD3	18 15/16	16 1/8	2 1/16	2 3/8" min.	21"

*Minimum acceptable spacing between adjacent SD2 models is 3 inches.

4. Before placing drop-in cooktop into cabinet, determine which one of the three knockout openings in the burner box (left side, right side or rear) will be used for routing of the gas supply tubing to the pressure regulator. After making selection, knockout the 1/2 inch plug. Place drop-in cooktop into the prepared opening and secure to cabinet with four (4) wood screws. (Not provided)

5. Route gas line through opening in burner box and connect the gas line to the 3/8" flare fitting inside the burner box. Place nylon brushing over gas line and insert brushing into opening in burner box.

CAUTION: Gas supply tubing within the confines of the appliance connection shall be rigid or semi-rigid metallic tubing.

6. Be sure all openings in the cabinetry around the gas line are sealed at time of installation.

CAUTION: It is imperative that the cabinet in which the cooktop is placed be separated from other appliances so that the combustion air supply to the top burners can not be affected in any way by any forced-air heating appliance or its return air system or by any other source of positive or negative air pressure. A negative air pressure created by another forced air appliance may draw the flame down around the top burners and into the cooktop resulting in damage to the burners and cooktop, as well as possible personal injury and/or damage to vehicle. A positive draft could cause the burner flame to lift-off the burner and go out resulting in an uncontrolled escape of gas. Whenever the gas fumes reach an open flame or another ignition source, an explosion and/or fire will occur resulting in property damage, personal injury and/or loss of life.

7. Be sure burner knobs are in "off" position. Turn on gas supply. Check all connections for leaks.

WARNING: Never check for leaks with an open flame. Apply a soap and water solution to all joints to see if bubbles are formed.

NOTE: The appliance must be disconnected from the gas supply piping system during any pressure testing of that system at test pressure in excess of 1/2 PSIG.

The appliance must be isolated from the gas supply piping during any pressure testing of the gas supply piping system at test pressure equal to, or less than, 1/2 PSIG.

8. Remove the top and the grate(s) from their packing.
 - a. Remove the protective rubber feet from the plastic bag and slip over the grate legs.
 - b. Install the grate(s) on the top.
 - c. Remove the grate retainer clips from the pack-out bag and install the clips over the burner grate legs from the underside of the stove top. Squeeze the ends of the clips together and slip over the ends of the burner grate.
9. Position the top over the burners and secure in place with two (2) thumb screws and two (2) nylon washers provided.
10. Your Suburban Drop-in Cooktop is now ready for operation. Before operating, read the safety information and operating instructions contained in this manual.

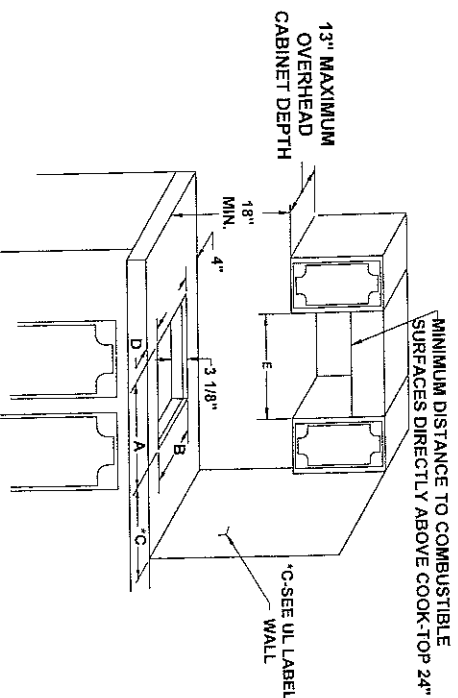

Figure 2

LIMITED WARRANTY
SUBURBAN RECREATIONAL VEHICLE RANGE APPLIANCE

LIMITED WARRANTY

This Suburban product is warranted to the original purchaser to be free from defects in material and workmanship under normal use and maintenance for a period of two years from date of purchase whether or not actual use begins on that date. All porcelain parts, including top burner grates, are warranted as commercially acceptable only as of the date the product was manufactured. It is the responsibility of the consumer/owner to establish the warranty period. Suburban does not use warranty registration cards for its standard warranty. You are required to furnish proof of purchase date through a Bill of Sale or other payment record.

Suburban will replace any parts that are found defective within the first two years and will pay a warranty service allowance directly to the authorized Suburban Service Center at rates mutually agreed upon between Suburban and its authorized service centers. Replacement parts will be shipped FOB the shipping point within the Continental United States, Alaska and Canada to authorized service centers performing such repairs. All freight, shipping and delivery costs shall be the responsibility of the owner. The exchanged part or unit will be warranted for only the unexpired portion of the original warranty. Before having warranty repairs made, confirm that the service agency is an authorized service center for Suburban. **DO NOT PAY THE SERVICE AGENCY FOR WARRANTY REPAIRS; SUCH PAYMENTS WILL NOT BE REIMBURSED.**

Suburban reserves the right to examine the alleged defect in the range appliance or component parts, and it is the owner's obligation to return the range appliance and/or component parts to Suburban or its representative. When returning a range appliance, it must include all component parts and the serial number plate. Returned component parts must be individually tagged and identified with the range appliance's model number, serial number and date of installation.

For warranty service, the owner/user should contact the nearest authorized Suburban Service Center, advising them of the model and serial numbers (located underneath the main top) and the nature of the defect. Transportation of the unit to and from the Service Center and/or travel expenses of the Service Center to your location is the responsibility of the owner. If you cannot locate an authorized service center locally, the service agency chosen to perform warranty repairs must contact our Service Department at 423-775-2131 for authorization. Unauthorized repairs made will not be paid by Suburban.

LIMITATION OF WARRANTIES

ALL IMPLIED WARRANTIES (INCLUDING IMPLIED WARRANTIES OF MERCHANTABILITY) ARE HEREBY LIMITED IN DURATION TO THE PERIOD FOR WHICH EACH LIMITED WARRANTY IS GIVEN. SOME STATES DO NOT ALLOW LIMITATIONS ON HOW LONG AN IMPLIED WARRANTY LASTS SO THE ABOVE LIMITATIONS MAY NOT APPLY TO YOU. THE EXPRESSED WARRANTIES MADE IN THIS WARRANTY ARE EXCLUSIVE AND MAY NOT BE ALTERED, ENLARGED, OR CHANGED BY ANY DISTRIBUTOR, DEALER OR OTHER PERSON WHOMSOEVER.

SUBURBAN WILL NOT BE RESPONSIBLE FOR:

1. Normal maintenance as outlined in the installation, operating and service instructions owner's manual including cleaning of component parts and cleaning or replacement of the burner orifice.
2. Initial checkouts and subsequent checkouts which indicate the range appliance is operating properly, or diagnosis without repair.
3. Damage or repairs required as a consequence of faulty or incorrect installation or application not in conformance with Suburban instructions.
4. **ANY DAMAGE (CRACKS, CHIPS, SCRATCHES, ETC.) TO ANY PAINTED OR PORCELAIN ENAMEL PARTS.**
5. Failure to operate due to loose or disconnected wires; water or dirt in controls, fuel lines and gas tanks; improper gas pressure; low voltage.
6. Cleaning or adjustment of components; electrode, burner tube, pilot and thermocouple.
7. Costs incurred in gaining access to the range appliance.
8. Parts or accessories not supplied by Suburban.
9. Freight charges incurred from parts replacements.
10. Damage or repairs needed as a consequence of any misapplication, abuse, unreasonable use, unauthorized alteration, improper service, improper operation or failure to provide reasonable and necessary maintenance.
11. Suburban products whose serial number has been altered, defaced or removed.
12. Suburban products installed or warranty claims originating outside the Continental U.S.A., Alaska, Hawaii and Canada.
13. Damage as a result of floods, winds, lightning, accidents, corrosive atmosphere or other conditions beyond the control of Suburban.
14. **ANY SPECIAL, INDIRECT OR CONSEQUENTIAL PROPERTY, ECONOMIC OR COMMERCIAL DAMAGE OF ANY NATURE WHATSOEVER.** Some states do not allow the exclusion of incidental or consequential damages, so the above limitation may not apply to you. **NO REPRESENTATIVE, DEALER OR OTHER PERSON IS AUTHORIZED TO ASSUME FOR SUBURBAN MANUFACTURING COMPANY ANY ADDITIONAL, DIFFERENT OR OTHER LIABILITY IN CONNECTION WITH THE SALE OF THIS SUBURBAN PRODUCT.**

This warranty gives you specific legal rights, and you may also have other rights which vary from state to state.

IF YOU HAVE A PRODUCT PROBLEM

FIRST:

If your RV has its original range appliance and is still under the RV manufacturer's warranty, follow the steps described in your RV owner's manual.

SECOND:

Contact a conveniently located recommended Suburban Service Center. Describe to them the nature of your problem, make an appointment, if necessary, and provide for delivery of the range appliance to the selected service center.

THIRD:

To obtain information on locating a local service agency, contact:

Suburban Manufacturing Company
Customer Service Department
Post Office Box 399
Dayton, Tennessee 37321
(423) 775-2131, Ext. 1

Escrowed copy 1/22/07 DM

Good copy