

DUO-THERM

INSTALLATION and OPERATING INSTRUCTIONS

SUNCHASER

ROOF MOUNT AIR CONDITIONER

Rotary XL (558 Series) and Classic (548 Series)

QUICK START MODELS

54812.041
55812.041
54815.041
54815.043
55815.041

SHUR START MODELS

54812.042
55812.042
54815.042
54815.044
55815.042

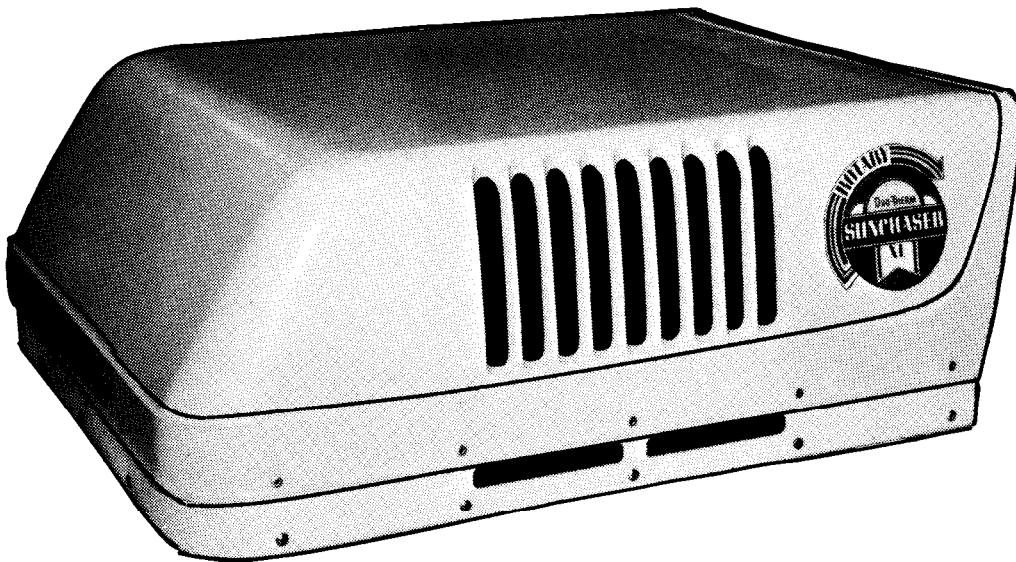

READ THESE INSTRUCTIONS CAREFULLY, KEEP FOR FUTURE REFERENCE.

A V I S :

Cet appareil doit être réparé seulement par un réparateur autorisé. Modification de l'appareil pourrait être extrêmement dangereuse. et pourrait Causer mal ou mort.

CAUTION

MODIFICATION OF THIS APPLIANCE CAN BE EXTREMELY HAZARDOUS. ALWAYS CONSULT THE MANUFACTURER BEFORE MAKING CHANGES.

SPECIFICATIONS

	Classic 54812-041 54812-042	Rotary XL 55812-041 55812-042	Classic 54815-041 54815-042	Classic 54815-043 54815-044	Rotary XL 55815-041 55815-042	HEATER CIRCUIT
Nominal BTU Capacity	11,000	11,000	13,500	13,500	13,500	5600
VOLTS	115	115	115	115	115	120
KILOWATTS	1.4	1.4	1.7	1.8	1.6	1.53
Run Amps-Comp./Mtr.(HI Speed)	10.2/1.95	10.2/1.95	12.8/2.3	13.5/2.3	12.4/2.3	14.8
LRA Compressor/Motor	50.0/4.2	56.6/4.2	59.5/5.5	72.5/5.5	63.5/5.5	-----
WIRE SIZE	Up to 24' - Use No. 12 AWG					
MINIMUM GENERATOR *	3500 WATT					
CIRCUIT PROTECTION	20 Amp Time Delay					
Refrigerant (R-22)	14.5 oz.	15.5 oz.	22.5 oz.	22.0 oz.	22.5 oz.	-----
MAX. ROOF THICKNESS	6"	6"	6"	6"	6"	
MIN. ROOF THICKNESS	1"	1"	1"	1"	1"	

* For two units USE 5000 watt generator

DUO-THERM TESTED UNDER ARI STANDARD 250-74

UL STANDARD 484

CSA STANDARD 22.2 No. 0,46 and 119

- Normally, roof mount air conditioners are installed where an existing roof vent has been removed. This creates the 14" x 14" opening required for installation (Fig. 1). If an opening has to be cut, be sure to check for proper clearance on the inside of the RV for the air box (Fig. 2) and on the outside for the unit. (Fig. 3).

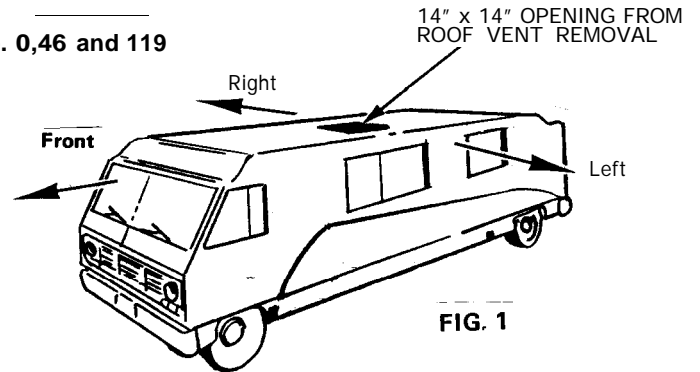
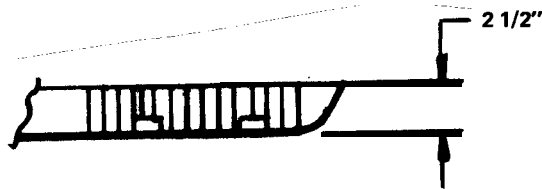

FIG. 1

FIG. 2

INTERIOR AIR BOX DEPTH



INTERIOR AIR BOX DIMENSIONS

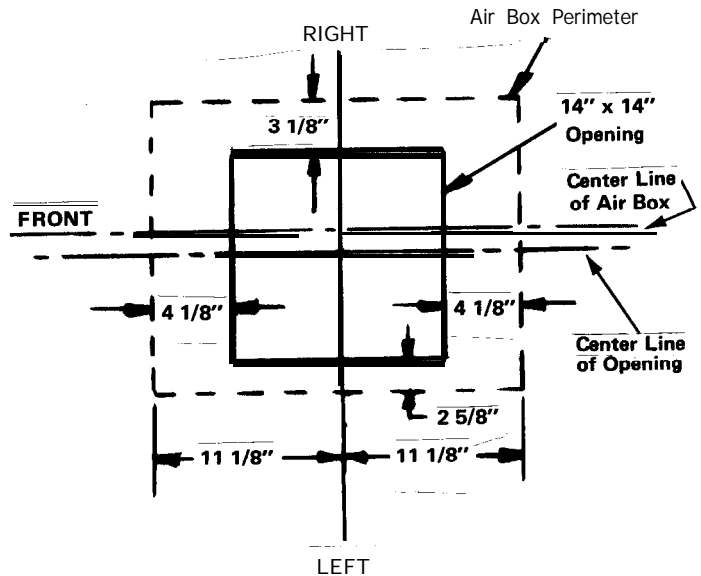
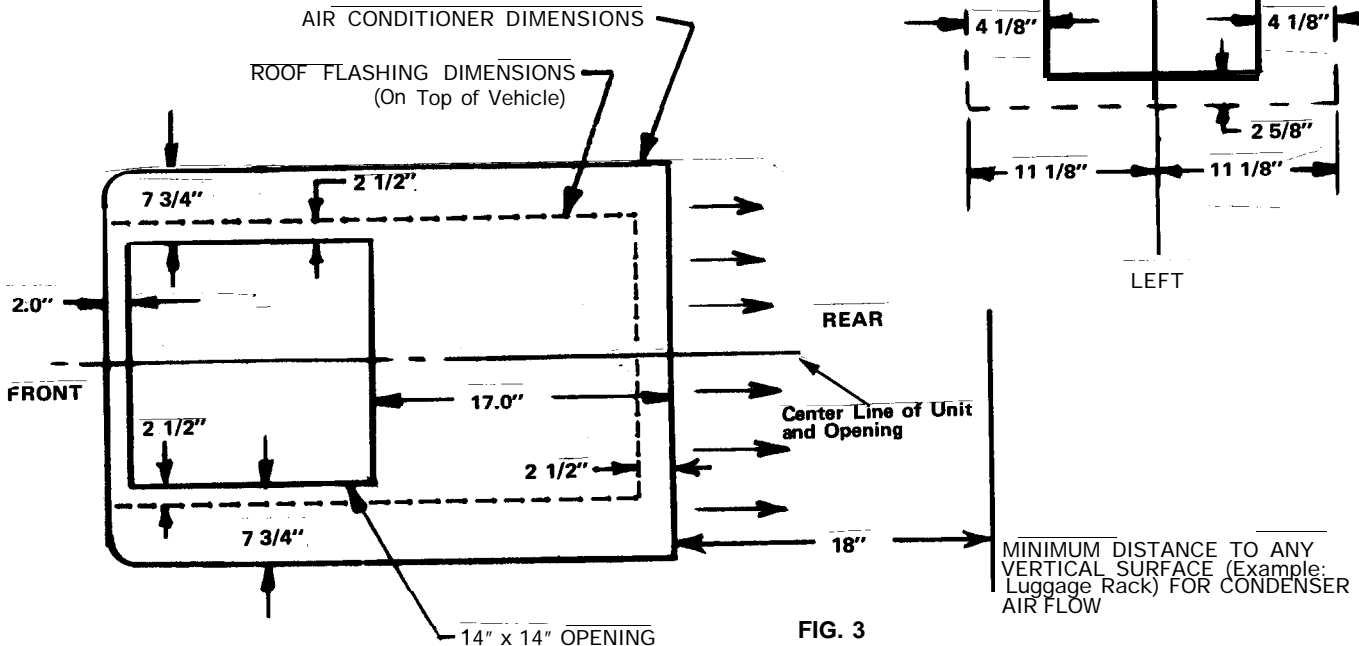
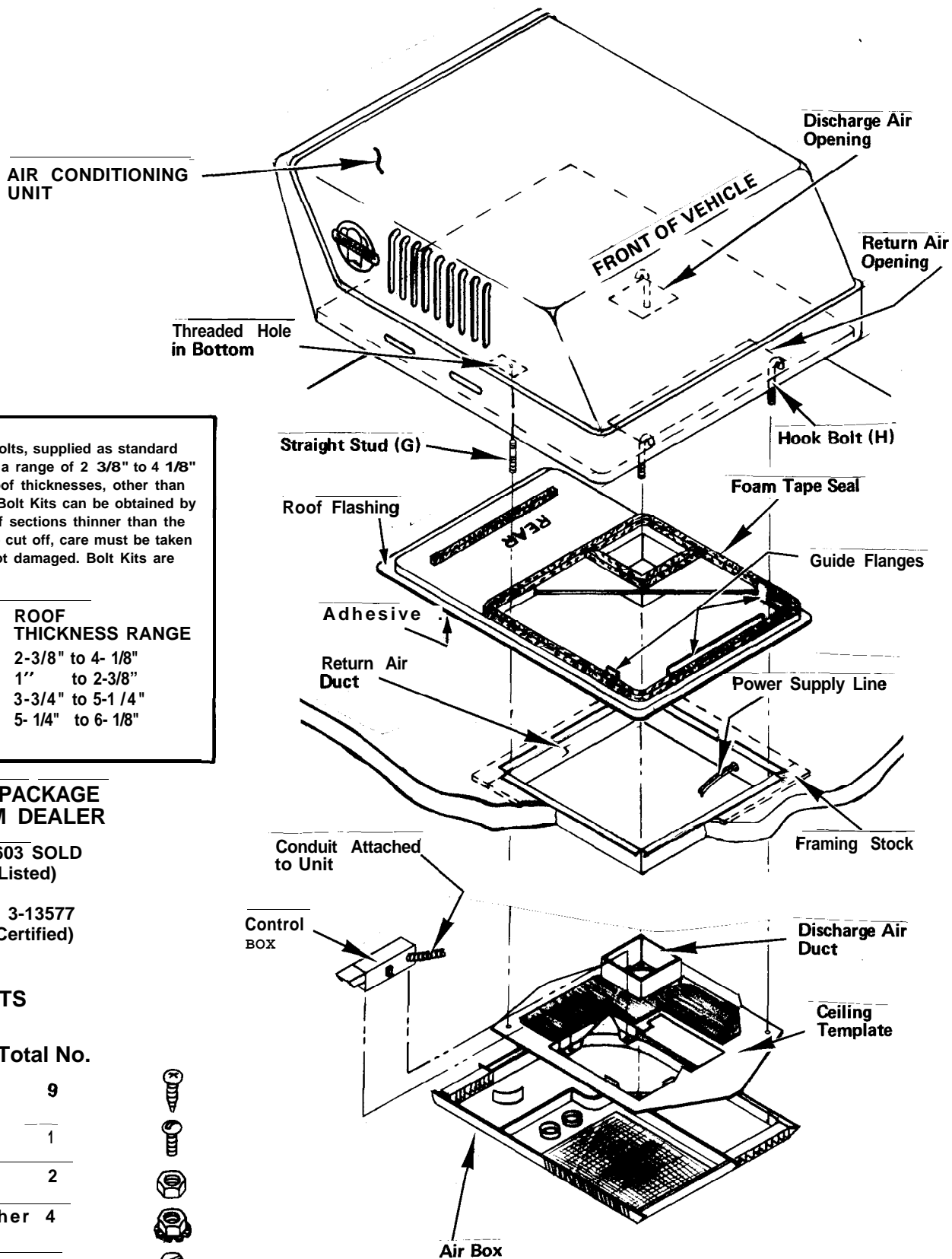

FIG. 3



INSTALLATION LAYOUT

Fig. 4



NOTE: The anchor bolts, supplied as standard equipment, will cover a range of 2 3/8" to 4 1/8" roof thickness. For roof thicknesses, other than the standard, special Bolt Kits can be obtained by special order. For roof sections thinner than the standard, bolts can be cut off, care must be taken so that threads are not damaged. Bolt Kits are available as follows:

KIT PART NO.	ROOF THICKNESS RANGE
3-14870(std)	2-3/8" to 4- 1/8"
3-14867(opt)	1" to 2-3/8"
314868(opt)	3-3/4" to 5-1/4"
314869(opt)	5- 1/4" to 6- 1/8"

OPTIONAL HEAT PACKAGE AVAILABLE FROM DEALER

PART NUMBER 3-15603 SOLD IN U.S.A. ONLY (UL Listed)

AIR BOX ASSEMBLY 3-13577 FOR CANADA (CSA Certified)

MOUNTING PARTS

	Total No.
(A) Wood Screw	9
(B) Machine Screw	1
(C) Hex Nut	2
(D) Nut & Lockwasher	4
(E) Self Taping Screw (Blunt Point)	4
(F) Wire Connector	2
(G) Anchor Bolt (Straight)	1
(H) Anchor Bolt (Hook)	3

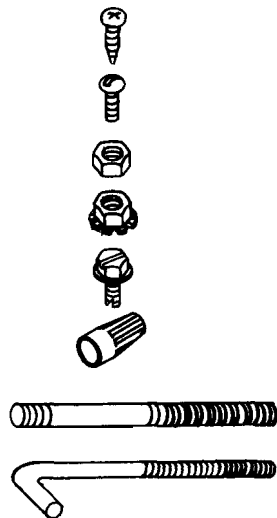

2. ROOF OPENING PREPARATION

Framing is required to provide adequate support and a smooth surface for sealing. Under no circumstances should the roof be constructed to create a low spot where water will accumulate. Any opening between the roof and ceiling should be framed to prevent hot or cold air from being drawn from the cavity. (Be sure to provide opening for electrical supply line.) (See Fig. 4).

3. In the carton you will find the "return air duct", an aluminum piece of sheet metal folded flat. Unfold and form into a square (approximately 14" x 14") to line the roof opening. Form tabs approximately 1" wide along top edge to rest against the roof. Place duct through opening then mark and remove any excess that protrudes beyond the ceiling. (Hole is provided for supply line.) (See Fig. 4).
4. Run power line to roof opening: If vent fan was removed, the existing wire may be used provided it complies with all National, State and Local wiring codes. **NOTE:** Be sure power supply is OFF. The power line should be a separate circuit using 12 AWG size wire and maximum circuit protection (20 AMP time delay).
5. Installation of roof flashing: (Reference Fig. 4) **CAUTION:** Be sure all roof seams are sealed and surface is clean before proceeding.
 - a. Peel off the protective wax paper from the adhesive on the bottom of roof flashing.

Place roof flashing over 14" x 14" opening – flanges on bottom will help assure proper alignment. Be sure marking "REAR" is toward rear of vehicle.
 - b. Once you are sure of proper alignment, press down around outer edges to help hold in place. Seal will be completed when unit is torqued down.
6. Install air conditioner on roof flashing: (Reference Fig. 4) Using the roof flashing guide flanges, position the air conditioner over the corresponding openings, **CAUTION:** Do not damage the foam tape sealer on the flashing as this makes the seal between it and unit. The outside installation is now complete and any minor positioning can be made from inside.

7. Ceiling Template Installation: Open the plastic bag of mounting parts and use the Installation Layout on Page 3 for reference.

- a. The control box which is permanently connected to the unit is wrapped in cardboard and stored in the return air opening for shipping. Pull down, being careful not to damage coil fins, and discard wrapper. Let hang until ceiling template is installed.
- b. Install the straight anchor bolt (G) into the threaded hole located opposite the discharge air opening in the bottom of the unit. Screw the end with 3/8" of thread in until finger tight. (See Fig. 5).
- c. Slide the ceiling template over this bolt and engage the discharge air duct to check for proper alignment. (The upper duct fits inside the lower.) Perforated tabs may be removed for thin roof sections. Remove both tabs for roofs 1" to 2" thick; remove 1 tab for roofs 2" to 3" thick, and as received for roofs 3" to 4 1/4" thick. For roof thickness greater than 4 1/4", a duct adaptor (Part No. 3-13606) is available upon request.
- d. If alignment is correct, proceed with installation; if slight adjustments are necessary, make these before continuing.
- e. Put Nut (D) on straight anchor bolt finger tight to hold template while installing the three (3) hook bolts (H) in the remaining corners. The nuts may be installed finger tight on the bolts to aid in holding the template. (See Fig. 5).
- f. Secure ceiling template with four (4) wood screws (A), two (2) in each end. (See Fig. 5).
- g. Evenly tighten the four (4) anchor bolt nuts (D) to secure the unit and insure a proper roof seal. Since these nuts have lock washers, do not over tighten, 75 in. lbs. or 6 1/4 ft. lbs. torque is recommended.

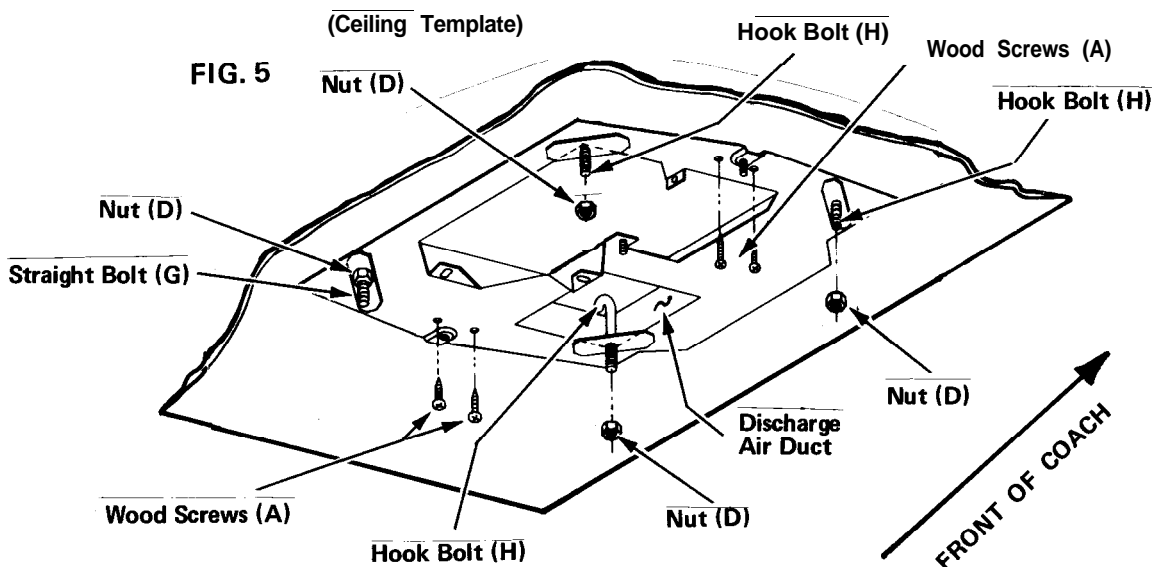

8. **Control Box Installation:** Fasten the control box to the ceiling template with two blunt point screws (E). (See Fig. 6). Install one screw (A) in the junction box (part of the control box) which holds it to the ceiling.
9. **Connect Power Supply:** As mentioned previously, all wiring must comply with the American National Standard Institute, National Electrical Codes and all local codes. NOTE: All required installation hardware is supplied.
 - a. The supply line should be routed to the junction box and secured by the cable connector provided. Six inch tails are sufficient for connection to unit wires and ground screw. (See Fig. 6).
 - b. Connect the white wire in the junction box to the white or neutral wire from the supply line with one of the twist type connectors provided.
 - c. Connect the black wire in the junction box to the black or hot wire from the supply line with the other twist connector.
 - d. Connect the ground wire to the identified ground screw.
 - e. Install junction box cover with two blunt point screws (E). (See Fig. 6).
10. **Place thermostat sensor tube in ceiling template bracket with small rubber grommet. (See Fig. 6).**

11. **Install Air Box: (Reference Fig. 7)** Mounting requires four (4) wood screws (A); one (1) machine screw (B); and two (2) hex nuts (C) to install the air box. (Reference Fig. 4).
 - a. Remove the return air grille held by two (2) quarter turn fasteners.
 - b. Remove the small cover plate at the end opposite the return air grille, Care must be used not to break the two mounting legs as this piece will be reinstalled later.
 - c. NOTE: If optional heat package is to be installed, do so before air box is installed. Refer to instructions provided with heat package accessory 3-15603.
 - d. Install air box over two weld studs on ceiling template and secure with nuts (C).
 - e. Install machine screw (B) in hole that was uncovered by small plate. Tighten screw and nuts.
 - f. Install four (4) wood screws (A) that hold air box tight to the ceiling.
 - g. Reinstall cover plate and return air grille.
 - h. You are now ready for operational check and many hours of comfort!

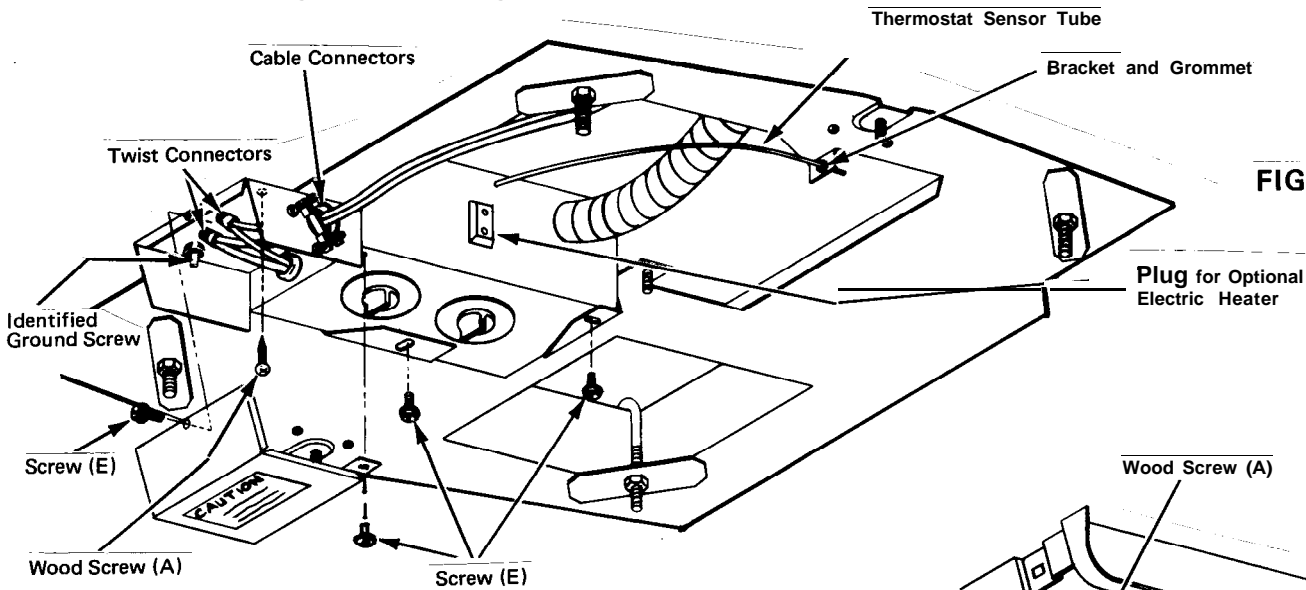
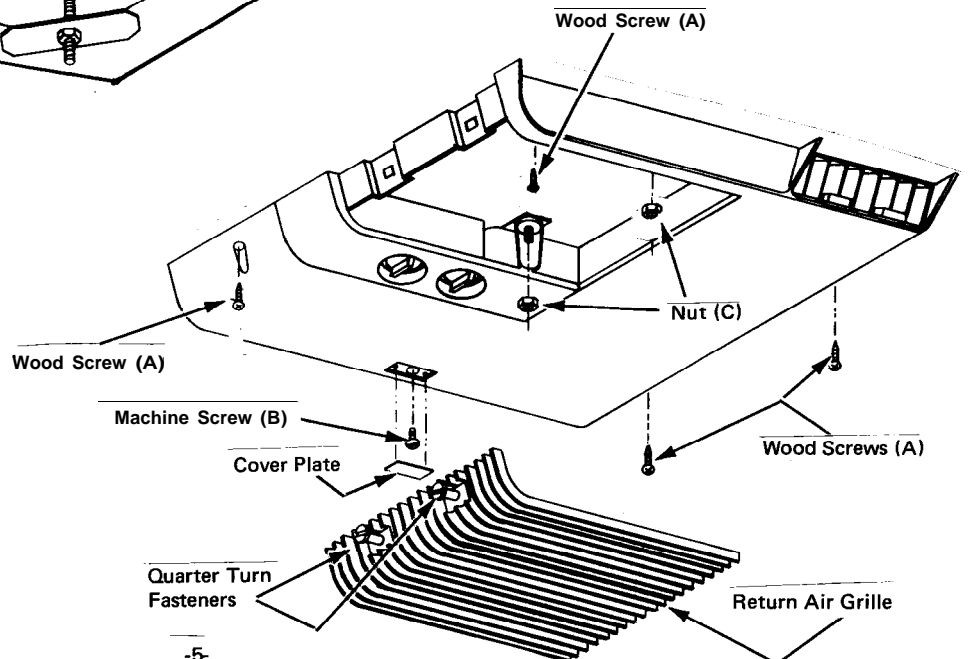

FIG. 6

FIG. 7



12. **FOR COOLED AND DEHUMIDIFIED AIR** set the thermostat dial to the desired temperature. The warmest setting (WARM) on the dial is approximately 95 degrees; the coolest setting (COLD) is approximately 70 degrees.

Place blower selector switch in desired position. High-cool, medium-cool or low-cool positions are used when air conditioning is desired. In these positions, the blower will operate continuously and the compressor will come on when the thermostat calls for cooling and off when the desired temperature has been reached.

FOR CIRCULATED AIR ONLY place the selector switch in the desired position. High Fan, Medium Fan and Low Fan positions will circulate inside air and not operate the compressor for cooling.

FOR HEATED AIR, with the optional heat package installed, place selector switch in the desired position. High Heat, Medium Heat and Low Heat positions will circulate the air and allow the heater to cycle on the thermostat that has been set at the desired temperature. Since actual BTU output is not affected by blower speed, it is recommended that Low Heat position be used. **NOTE:** On units that do not have the optional heat package installed, these positions will act to circulate the inside air only.

Adjust the louvers at the air discharge openings for best air distribution. (These louvers should never be completely closed).

TO COMPLETELY SHUT DOWN THE UNIT, place the blower switch in the "OFF" position.

NOTE: Shur-Start models have a delayed start kit installed. When the unit is turned on, the fan will start and in approximately two (2) minutes, the compressor will start. After the compressor has shut down, it will not restart for approximately two (2) minutes. This allows pressures to equalize in the refrigerant system and eases the starting load for the compressor.

Quick-Start models do not have the delayed start feature. When the unit is turned on, the fan and compressor start at the same time. After shutdown, wait three (3) to four (4) minutes before restarting unit to allow pressure equalization.

13. **Air Filter** – Your air conditioner will operate more efficiently with a clean filter. Periodically remove and wash the filter with soap and warm water, let dry and reinstall. Replacement filters are available from your R.V. Dealer, DUO-THERM Service Center or Distributor. Order Part No. 3-8166.

Motor Lubrication – The motor has sealed-bearings and with normal usage will not require oiling. On some motors oilers may be included and can be lubricated with non-detergent SAE 20 motor oil if you desire.

Protective Cover – To keep outdoor portion of your air conditioner free from foreign material during the off-season, a protective vinyl cover is available as an optional item. Order Part Number 3-9937 for the 54812, 54815, 55812 and 55815 Series. **NOTE:** Be sure to remove cover before operating the unit.

If service work is needed refer to the 19-1073 Service Directory supplied, with the unit for the name of the nearest authorized service enter. When requesting service, always give complete model and serial numbers located on the plate at the rear of the outdoor portion of the air conditioner.

WIRING DIAGRAM

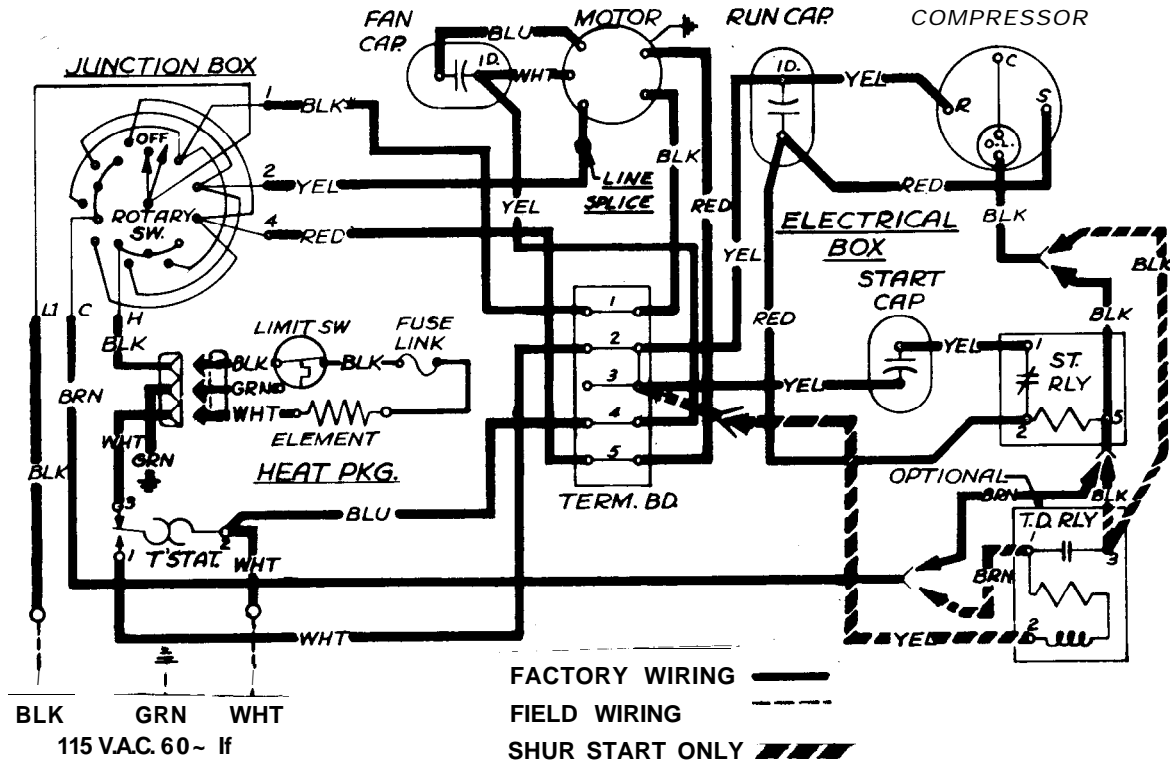

CIRCUIT DIAGRAM

